



Bulletin 4660-MiniKrimp

Crimping Machine Technical Manual

Effective: April 2003

MiniKrimp™



WARNING -- When operating this machine, always exercise basic safety precautions to minimize the possibility of injury, including the following:

1. When using a power unit, use only Parker recommended power units to hydraulically operate Parker crimpers.
2. When using a power unit, connect the power unit to a grounded, properly rated, protected and sized power-supply circuit to prevent electrical shock and to avoid electrical overload.
3. **DO NOT OPERATE MINIKRIMP™ OVER MAXIMUM RATED WORKING PRESSURE OF 10,000 PSI.**
4. Wear safety glasses.

Make sure that the valve connecting the hose or tube assembly and other components are protected from any external source of damage, such as: excessive heat, flame, moving machine parts, sharp edges, falling objects, corrosive chemicals, dropping, and other hazards.

 **WARNING**

FAILURE OR IMPROPER SELECTION OR IMPROPER USE OF THE PRODUCTS AND/OR SYSTEMS DESCRIBED HEREIN OR RELATED ITEMS CAN CAUSE DEATH, PERSONAL INJURY AND PROPERTY DAMAGE.

Before selecting or using any Parker hose or fittings or related accessories, it is important that you read and follow *Parker Safety Guide for Selecting and Using Hose, Fittings, and Related Accessories* (Parker Publication No. 4400-B.1)

This document and other information from Parker Hannifin Corporation, its subsidiaries and authorized distributors provide product and/or system options for further investigation by users having technical expertise. It is important that you analyze all aspects of your application and review the information concerning the product or system in the current product catalog. Due to the variety of operating conditions and applications for these products or systems, the user, through its own analysis and testing, is solely responsible for making the final selection of the products and systems and assuring that all performance, safety and warning requirements of the application are met.

The products described herein including without limitation, product features, specifications, designs, availability and pricing, are subject to change by Parker Hannifin Corporation and subsidiaries at any time without notice.

Offer of Sale

The items described in this document are hereby offered for sale by Parker Hannifin Corporation, its subsidiaries or its authorized distributors. This offer and its acceptance are governed by the provisions in the "Offer of Sale."

MiniKrimp™ Hand Pump Model - Overview	2
MiniKrimp™ Air over Hydraulic Model - Overview	3
Accessories	4-6
Tools and Dies	7-10
Crimping Instructions	11
MiniKrimp™ Assembly Detail and Parts List	12
Air over Hydraulic MiniKrimp™ Assembly	13
Trouble Shooting Guide	14
Safety Guide (Parker Publication 4400-B.1)	15-18
MSDS Statement	18
Offer of Sale	19

Help us help you . . .

Read this guide carefully before using.

This Technical Manual is designed to help you operate and maintain your MiniKrimp™. If you need more information or further assistance, please contact us:

For the nearest authorized Enerpac Service Center, please contact Enerpac:

Call:

Technical Services Department
Parker Hannifin Corporation
Parflex Division
Phone: (330) 298-4066 or (330) 296-2871
Fax: (330) 296-8433

Call:

Enerpac Service Center
Phone: (800) 558-0530

E-mail:

www.Enerpac.com

Write:

Technical Services Department
Parker Hannifin Corporation
Parflex Division
1300 N. Freedom St.
Ravenna, OH 44266

E-mail:

dmay@parker.com

RECEIVING INSTRUCTIONS:

UNPACKING — Carefully remove all documents and components from shipping containers.

INSPECTION — Visually inspect all components for shipping damage. If any shipping damage is found, notify the carrier at once. The carrier is responsible for all repair and replacement costs resulting from such damage. Shipping damage is not covered by the Parker warranty.



MiniKrimp™ — Hand Pump Model

For use with Parker HY, 43, 55, 57, 58, and 91N Series Fittings

With its cast aluminum design, the MiniKrimp is lightweight, portable, and compact. This all-in-one unit is capable of crimping Parflex Division hose sizes up to 1". Note: Dies are sold separately.

Specifications

Approximate Size (with Pump)	6" wide, 13" deep, 15" high
Weight (w/o Die Set)	42 lbs. with hand pump
Rating	30 tons force @ 10,000 psi maximum
Capability (steel & brass) HY, 43, 55, 57, 58, 91N series fittings	- 1" SAE 100R1 maximum - 1" SAE 100R2 maximum - 1" SAE 100R7 maximum - 1" SAE 100R8 maximum - 1" SAE 100R12 maximum - 1" SAE 100R14 maximum - 1" SAE 100R16 maximum - 1" SAE 100R17 maximum - 1" SAE 100R18 maximum
Capability (stainless steel) HY, 55, 57, 58, 91N series fittings	- 3/4" SAE 100R1 maximum - 3/4" SAE 100R2 maximum - 3/4" SAE 100R7 maximum - 3/4" SAE 100R8 maximum - 3/4" SAE 100R14 maximum - 3/4" SAE 100R16 maximum - 3/4" SAE 100R17 maximum - 3/4" SAE 100R18 maximum
Set Up Time	20 seconds
Full Cycle Time	Approx. 20 seconds to 3 minutes. Note: Cycle times vary depending on hose, fitting, operator, and crimping environment.

Standard Equipment

Model 94C-001-PFD includes:

Part Description	Part Number
MiniKrimp™ Portable Crimping Machine	94C-080-PFD
Hand Pump Only	015301
Die Ring – Color Coded Silver	82C-R01-PFD

Optional Equipment:

Part Description	Part Number
Side Vise Mount	015736
Upright Table Mount	015306
Upright Vise Mount	015307
Die Ring – Color Coded Black	82C-R02-PFD
Hose Assembly	015309

For HY, 43, 55, 57, 58, and 91N Series tooling and crimping information, refer to Parker Parflex Catalog 4660 or the "Tools and Dies" section of this manual.

For MiniKrimp usage with HPD's offering of hose, fittings, and tooling and for crimping information, refer to Parker Hose Products Catalog 4400, Section C.

Current hose and fitting combinations, as well as proper crimp dimensions, are available from Parker Parflex Division for thermoplastic hose, and Parker Hose Products Division for rubber hose. Contact 1-800-C-PARKER for direction on obtaining current literature.

Note: Reference the following manual sections: "Accessories" for information on Hand Pump (015301 and 85C-0HP), Electric Pump (82C-0EP and 85C-0EP), and Air/Hydraulic Pump (82C-0AP and 025399); "Crimping Instructions" for assembly instructions using the MiniKrimp; "MiniKrimp Assembly Detail & Parts List" for a complete listing of parts.

All pumps are supplied to Parker by Enerpac. For repair or warranty work to any of the cylinders or pumps, contact your nearest Enerpac Service Center. For the Enerpac Service Center nearest you, call 1-800-558-0530 or visit the Enerpac web site at www.Enerpac.com.



MiniKrimp™ — Air over Hydraulic Model

For use with Parker HY, 43, 55, 57, 58, and 91N Series Fittings

With its cast aluminum design, the MiniKrimp™ Air over Hydraulic is lightweight, portable, and compact. This all-in-one unit is capable of crimping Parflex Division hose sizes up to 1". Note: Dies are sold separately.

Specifications

Approximate Size with Pump:	6" wide, 12" deep, 15" high
Weight	45 lbs. with air/hydraulic pump
Rating	30 tons force @ 10,000 psi maximum
Capability (steel & brass) HY, 43, 55, 57, 58, 91N series fittings	- 1" SAE 100R1 maximum - 1" SAE 100R2 maximum - 1" SAE 100R7 maximum - 1" SAE 100R8 maximum - 1" SAE 100R12 maximum - 1" SAE 100R14 maximum - 1" SAE 100R16 maximum - 1" SAE 100R17 maximum - 1" SAE 100R18 maximum
Capability (stainless steel) HY, 55, 57, 58, 91N series fittings	- 3/4" SAE 100R1 maximum - 3/4" SAE 100R2 maximum - 3/4" SAE 100R7 maximum - 3/4" SAE 100R8 maximum - 3/4" SAE 100R14 maximum - 3/4" SAE 100R16 maximum - 3/4" SAE 100R17 maximum - 3/4" SAE 100R18 maximum
Set Up Time	20 seconds
Full Cycle Time	Approx. 20 seconds to crimp a 3/8" hose Note: Cycle times vary depending on hose and fitting styles and sizes.

Standard Equipment

Model 94C-002-PFD includes:

Part Description	Part Number
MiniKrimp™ Portable Crimping Machine	94C-080-PFD
Air over Hydraulic Pump Kit (includes tubing and adapters)	025411
Die Ring – Color Coded Silver	82C-R01-PFD

Optional Equipment:

Part Description	Part Number
Side Vise Mount	015736
Upright Table Mount	015306
Upright Vise Mount	015307
Die Ring – Color Coded Black	82C-R02-PFD
Hose Assembly	015309

For HY, 43, 55, 57, 58, and 91N Series tooling and crimping information, refer to Parker Parflex Catalog 4660 or the "Tools and Dies" section of this manual.

For MiniKrimp usage with HPD's offering of hose, fittings, and tooling and for crimping information, refer to Parker Hose Products Catalog 4400, Section C.

Current hose and fitting combinations, as well as proper crimp dimensions, are available from Parker Parflex Division for thermoplastic hose, and Parker Hose Products Division for rubber hose. Contact 1-800-C-PARKER for direction on obtaining current literature.

Note: Reference the following manual sections: "Accessories" for information on Hand Pump (015301 and 85C-0HP), Electric Pump (82C-0EP and 85C-0EP), and Air/Hydraulic Pump (82C-0AP and 025399); "Crimping Instructions" for assembly instructions using the MiniKrimp; "MiniKrimp Assembly Detail & Parts List" for a complete listing of parts.

All pumps are supplied to Parker by Enerpac. For repair or warranty work to any of the cylinders or pumps, contact your nearest Enerpac Service Center. For the Enerpac Service Center nearest you, call 1-800-558-0530 or visit the Enerpac web site at www.Enerpac.com.

Hand Pump

Part No. 015301

Easy-to-use hand pump delivers 10,000 psi.



Length 13-3/8"
 Width 3-1/4"
 Height 3-5/8"
 Port size 1/4" NP
 Weight 4.7 lbs.
 Hydraulic Fluid Enerpac Oil

Hand Pump

Part No. 85C-0HP-PFD

Easy-to-use hand pump delivers 10,000 psi.



Length 28-15/16"
 Width 12-1/8"
 Height 11"
 Port Size 3/8" NPTF
 Weight 61 lbs.
 Hydraulic Fluid Enerpac Oil

Reference Parker Hose Products Catalog 4400 for these additional pump options:

Pump Description	Part Number
Electric Pump	82C-0EP
Electric Pump	85C-0EP

Air/Hydraulic Pump

Part No. 82C-0AP-PFD

Lightweight pump operates with 80 – 120 psi shop air pressure.



Length 14-3/4"
 Width 5-5/8"
 Height 5-3/4"
 Weight 14 lbs.
 Intake Port Size 1/4" NPTF
 Output Port Size 3/8" NPTF
 Hydraulic Fluid Enerpac Oil

Air over Hydraulic Pump

Part No. 025399

Lightweight pump operates with 80 – 120 psi shop air pressure.



Length 13"
 Width 4-1/2"
 Height 5"
 Weight 12 lbs.
 Intake Port Size 1/4" NPTF
 Output Port Size 1/8" NPTF
 Hydraulic Fluid Enerpac Oil

*All pumps are supplied to Parker by Enerpac. For repair or warranty work to any of the cylinders or pumps, contact your nearest Enerpac Service Center. For the Enerpac Service Center nearest you, call 1-800-558-0530 or visit the Enerpac web site at www.Enerpac.com.

ENERPAC Warranty Policy

For those ENERPAC items sold as part of the Parker Parflex Division product offering, the following warranty applies.

ENERPAC products are warranted to be free of defects in materials and workmanship under normal use for as long as they are owned by the original purchaser, subject to the exclusions and limitations described below. This warranty does not cover ordinary wear and tear, overloading, alterations, (including repairs or attempted repairs by parties other than ENERPAC or its authorized service representatives), improper fluid, use in a manner for which they are not intended or use which is contrary to instructions for the products.

THIS WARRANTY IS LIMITED TO NEW PRODUCTS SOLD THROUGH ENERPAC AUTHORIZED DISTRIBUTORS, ORIGINAL EQUIPMENT MANUFACTURERS OR OTHER DESIGNATED CHANNELS OF DISTRIBUTION. NO AGENT, EMPLOYEE, OR OTHER REPRESENTATIVE OF ENERPAC HAS THE AUTHORITY TO IN ANY WAY CHANGE OR AMEND THIS WARRANTY.

Electronic products and components are warranted against defects in material and workmanship for a period of two years from the date of purchase.

The following items supplied with ENERPAC products are excluded from this warranty:

- Components not manufactured by ENERPAC, including air motors, electric motors, gasoline engines, and diesel engines. Such items are warranted to the extent of the warranty provided by the manufacturers of such items.

If the customer believes a product is defective, the product must be delivered, or shipped freight prepaid, to the nearest ENERPAC Authorized Service Center. The customer should contact ENERPAC to locate an Authorized Service Center in the customer's area. Products that do not conform to this

warranty will be returned by ground transportation, freight prepaid.

THE FOREGOING WARRANT IS EXCLUSIVE AND IS IN LIEU OF ALL OTHER EXPRESS AND IMPLIED WARRANTIES, INCLUDING BUT NOT LIMITED TO THE IMPLIED WARRANTIES OF MERCHANTABILITY AND FITNESS FOR A PARTICULAR PURPOSE.

The remedy of repair, replacement or refund is customer's exclusive remedy in the event of breach of this warranty.

SELLER SHALL NOT BE SUBJECT TO AND DISCLAIMS:

- (a) ANY OTHER OBLIGATIONS OR LIABILITIES ARISING OUT OF BREACH OF CONTRACT OR OF WARRANTY,
- (b) ANY OBLIGATIONS WHATSOEVER ARISING FROM TORT CLAIMS (INCLUDING NEGLIGENCE AND STRICT LIABILITY) OR ARISING UNDER THEORIES OF LAW WITH RESPECT TO PRODUCTS SOLD OR SERVICES RENDERED BY SELLER OR ANY UNDERTAKINGS, ACTS OR OMISSIONS RELATING THERETO, AND
- (c) ALL CONSEQUENTIAL, INCIDENTAL AND CONTINGENT DAMAGES WHATSOEVER.

ENERPAC's liability in all cases is limited to, and shall not exceed, the purchase price paid.

For the nearest authorized ENERPAC SERVICE CENTER, please call ENERPAC at 800-558-0530 or visit the ENERPAC WEB SITE at www.Enerpac.com.

Upright Vise Mount

Part No. 015307

(for use with MiniKrimp™ only)



Weight 1.7 lbs.

3/8"-16 UNC 1" long bolts are required for mounting bracket to crimper. Mounting bolts are **not** included.

Upright Table Mount

Part No. 015306

(for use with MiniKrimp™ only)



Weight 2.2 lbs.

3/8"-16 UNC 1" long bolts are required for mounting bracket to crimper. Mounting bolts are **not** included.

Side Vise Mount

Part No. 015736

(for use with MiniKrimp™ only)



Weight 1.4 lbs.

1/4"-20 UNC 1" long bolts are required for mounting bracket to crimper. Mounting bolts are **not** included.

Attachable Hose Assembly

Part No. 015309

(for use with MiniKrimp™ only)



Size 1/4" I.D.

Pressure Rating 10,000 psi W.P.

Length 6 ft.

End Connections: 1/4" NPTF

Bent Tube

Part No. 015308

(for use with MiniKrimp™ Hand Pump Model only)



Bent Tube

Part No. 025349

(for use with MiniKrimp™ Air Over Hydraulic Model only)



Parflex Hose Crimp Assembly Tool Selection Chart						
Hose	Size	Fitting	Crimp DIE 80C-	Crimp Diameter	Color	Die Ring Color
3CNG/CNGLT/CNGFR	-4	55	P04	.560/.580	Red	Silver
3CNG/CNGLT/CNGFR	-6	58	PO6H	.785/.805	Yellow	Silver
4CNG/CNGLT/CNGFR	-6	58	PO6H	.785/.805	Yellow	Silver
5CNG/CNGLT/CNGFR	-3	55	P03	.480/.500	Gray	Silver
5CNG/CNGLT/CNGFR	-4	58	P04H	.668/.688	Red	Silver
5CNG/CNGLT/CNGFR	-6	58	PO6H	.785/.805	Yellow	Silver
5CNG/CNGLT/CNGFR	-8	58	PO8H	.900/.920	Blue	Silver
510A/510C/518C	-2	58	P02H	.395/.415	Brown	Silver
510/510A/510C/518C	-3	55	P03	.480/.500	Gray	Silver
510/510A/510C/518C	-4	55	P04J	.535/.555	Red	Silver
510C/518C	-5	55	P05	.620/.640	Purple	Silver
510/510A/510C/518C	-6	55	P06	.675/.695	Yellow	Silver
510/510A/510C/518C	-8	55	PO8	.840/.860	Blue	Silver
510C/518C	-12	55	P12	1.100/1.120	Green	Silver
510C/518C	-16	55	P16	1.345/1.365	Black	Silver
520N/528N	-3	55	P03	.480/.500	Gray	Silver
520N/528N	-4	55	P04	.560/.580	Red	Silver
520N/528N	-5	55	P05	.620/.640	Purple	Silver
520N/528N	-6	55	PO6	.675/.695	Yellow	Silver
520N/528N	-8	55	PO8	.840/.860	Blue	Silver
520N/528N	-10	55	P10	.950/.970	Orange	Silver
526BA	-3	55	P03	.480/.500	Gray	Silver
526BA	-4	55	P04	.560/.580	Red	Silver
526BA	-6	55	P06	.675/.695	Yellow	Silver
53FR/530	-6	58	P06FR	.730/.750	Yellow	Silver
53FR/530	-8	58	PO8H	.900/.920	Blue	Silver
53FR/530	-12	58	P12H	1.150/1.170	Green	Silver
53LT/538LT	-3	55	P03	.480/.500	Gray	Silver
53LT/538LT	-4	55	P04	.560/.580	Red	Silver
53LT/538LT	-5	58	P05R	.650/.670	Purple	Silver
53LT/538LT	-6	58	P06FR	.730/.750	Yellow	Silver
53LT/538LT	-8	58	PO8H	.900/.920	Blue	Silver
53LT/538LT	-10	58	P10H	1.000/1.020	Orange	Silver
540N	-2	58	P02H	.395/.415	Brown	Silver
540N	-3	55	P03	.480/.500	Gray	Silver
540N/549	-4	55	P04	.560/.580	Red	Silver
540N	-5	55	P05	.620/.640	Purple	Silver
540N/549	-6	55	PO6	.675/.695	Yellow	Silver
540N/549	-8	55	PO8	.840/.860	Blue	Silver
540N	-12	55	P12	1.100/1.120	Green	Silver
540P	-4	55	P04	.560/.580	Red	Silver
540P	-6	55	PO6	.675/.695	Yellow	Silver
540P	-8	55	PO8	.840/.860	Blue	Silver
549	-2	57	P02H	.395/.415	Brown	Silver
55LT	-2	58	P02H	.395/.415	Brown	Silver
550H/55LT	-3	55	P03	.480/.500	Gray	Silver
550H/55LT	-4	55	P04	.560/.580	Red	Silver
550H/55LT	-5	55	P05	.620/.640	Purple	Silver
550H/55LT	-6	55	PO6	.675/.695	Yellow	Silver
550H/55LT	-8	55	PO8	.840/.860	Blue	Silver
550H	-10	58	P10H	1.000/1.020	Orange	Silver
550H/55LT	-12	55	P12	1.100/1.120	Green	Silver
550H	-16	55	P16	1.345/1.365	Black	Silver
55FR	-4	55	P04	.560/.580	Red	Silver
55FR	-6	55	PO6	.675/.695	Yellow	Silver
55FR	-8	55	PO8	.840/.860	Blue	Silver
560	-3	55	P03	.480/.500	Gray	Silver
560	-4	55	P04	.560/.580	Red	Silver

(Chart is continued on the following page.)

Parflex Crimp Dies can be identified by machined grooves in the top of dies: 55 Series has one groove, 58 Series has two grooves, 91N Series has three grooves and HY Series is flat. For 43 Series tooling and crimping information not listed above, refer to Parker Hose Products Catalog 4400, Section C.

Parflex Hose Crimp Assembly Tool Selection Chart (Continued)

Hose	Size	Fitting	Crimp DIE 80C-	Crimp Diameter	Color	Die Ring
560	-5	55	P05	.620/.640	Purple	Silver
560	-6	55	P06	.675/.695	Yellow	Silver
560	-8	55	P08J	.815/.835	Blue	Silver
560	-10	55	P10	.950/.970	Orange	Silver
560	-12	58	P12H	1.150/1.170	Green	Silver
570A	-6	55	P06	.675/.695	Yellow	Silver
570A	-8	55	P08J	.815/.835	Blue	Silver
575X **	-3	55	P03	.480/.500	Gray	Silver
575X	-4	55	P04	.560/.580	Red	Silver
575X	-6	55	P06	.675/.695	Yellow	Silver
575X	-8	55	P08	.840/.860	Blue	Silver
580N/588N	-4	58	P04H	.668/.688	Red	Silver
580N/588N	-6	58	P06H	.785/.805	Yellow	Silver
580N/588N	-8	58	P08H	.900/.920	Blue	Silver
580N/588N	-10	58	P10H	1.000/1.020	Orange	Silver
580N/588N	-12	58	P12H	1.150/1.170	Green	Silver
580N/588N **	-16	58	P16H	1.475/1.495	Black	Silver
590	-3	55	P03	.480/.500	Gray	Silver
590	-4	55	P04	.560/.580	Red	Silver
590	-6	55	P06	.675/.695	Yellow	Silver
590	-8	55	P08J	.815/.835	Blue	Silver
590	-10	58	P10H	1.000/1.020	Orange	Silver
590 **	-12	58	P12H	1.150/1.170	Green	Silver
590 **	-16	58	P16J	1.450/1.470	Black	Silver
GPH	-3	55	P03J	.445/.465	Gray	Silver
GPH	-4	55	P04J	.535/.555	Red	Silver
GPH	-5	55	P05	.620/.640	Purple	Silver
GPH	-6	55	P06	.675/.695	Yellow	Silver
GPH	-8	55	P08J	.815/.835	Blue	Silver
GPH	-10	55	P10	.950/.970	Orange	Silver
GPH	-12	55	P12	1.100/1.120	Green	Silver
HGPH	-4	55	P04	.560/.580	Red	Silver
GPH	-3	HBL	GPH3	.390/.410	Gray	Silver
GPH	-4	HBL	GPH4	.490/.510	Red	Silver
GPH	-5	HBL	GPH5	.560/.580	Purple	Silver
GPH	-6	HBL	GPH6	.625/.645	Yellow	Silver
GPH	-8	HBL	GPH8	.750/.770	Blue	Silver
GPH	-10	HBL	GPH10	.895/.915	Orange	Silver
GPH	-12	HBL	GPH12	1.060/1.080	Green	Silver
GPH	-16	HBL	GPH16	1.335/1.355	Red	Silver
MSH	-5	MS	M05	.535/.555	Purple	Silver
MSH	-6	MS	M06	.640/.660	Yellow	Silver
PDH	1.5	SF	P01H	.295/.315	–	Silver
PDH	-2	58	P02H	.395/.415	Brown	Silver
HPSH	-12	58	P12H	1.150/1.170	Green	Silver
HPSH	-16	58	P16J	1.450/1.470	Black	Silver
3PSH	-12	58	P12H	1.150/1.170	Green	Silver
3PSH	-16	58	P16J	1.450/1.470	Black	Silver
4PSH	-8	58	P08H	.900/.920	Blue	Silver
PTH	-3	92	T05	.450/.470	Purple	Silver
901N	-4	91N	T04N	.335/.355	Red	Silver
919	-3	91	T03	.295/.305	Gray	Silver
919/929	-4	91N	T04N	.335/.355	Red	Silver
919	-5	91N	T05N	.385/.405	Purple	Silver
919/929	-6	91N	T06N	.470/.490	Yellow	Silver
919/929	-8	91N	T08N	.565/.585	Blue	Silver
919	-10	91N	T10N	.665/.685	Orange	Silver

(Chart is continued on the following page.)

Parflex Crimp Dies can be identified by machined grooves in the top of dies: 55 Series has one groove, 58 Series has two grooves, 91N Series has three grooves and HY Series is flat. For 43 Series tooling and crimping information not listed above, refer to Parker Hose Products Catalog 4400, Section C.

Parflex Hose Crimp Assembly Tool Selection Chart (Continued)

Hose	Size	Fitting	Crimp DIE 80C-	Crimp Diameter	Color	Die Ring
919	-16	91N	T16N	1.045/1.065	Black	Silver
929	-16	91N	T16H	1.100/1.120	Black	Silver
919	-20	91	T20	1.415/1.435	White	Silver
919J/929BJ	-4	91N	T04J	.335/.355	Red	Silver
919J/929BJ	-5	91N	T05J	.385/.405	Purple	Silver
919J/929BJ	-6	91N	T06J	.470/.490	Yellow	Silver
919J/929BJ	-8	91N	T08J	.565/.585	Blue	Silver
919J/929BJ	-10	91N	T10J	.665/.685	Orange	Silver
919J/929BJ	-12	91N	T12J	.790/.810	Green	Silver
919J	-16	91N	T16J	1.045/1.065	Black	Silver
929BJ	-16	91N	T16HJ	1.100/1.20	Black	Silver
1035HT	-3	55	P03	.480/.500	Gray	Silver
1035A/HT	-4	55	P04	.560/.580	Red	Silver
1035A/HT	-6	55	P06	.675/.695	Yellow	Silver

Parflex HYBRID Hose Crimp Assembly Tool Selection Chart

Hose	Size	Fitting	Crimp DIE 80C-	Crimp Diameter	Color	Die Ring Color
D604	-4	HY	P0580	0.570/0.590	Red	Silver
D606	-6	HY	P0740	0.730/0.750	Yellow	Silver
D608	-8	HY	P0870	0.860/0.880	Blue	Silver
D610	-10	HY	P1045	1.035/1.055	Orange	Silver
D612	-12	HY	P1220	1.210/1.230	Green	Silver
D616	-16	HY	P1525	1.515/1.535	Black	Silver
HFS04	-4	HY	P0580	0.570/0.590	Red	Silver
HFS06	-6	HY	P0740	0.730/0.750	Yellow	Silver
HFS08	-8	HY	P0845	0.835/0.855	Blue	Silver
HFS12	-12	HY	P1130	1.120/1.140	Green	Silver
HFS16	-16	HY	P1395	1.385/1.405	Black	Silver
HFS204	-4	HY	P0625	0.615/0.635	Red	Silver
HFS206	-6	HY	P0740	0.730/0.750	Yellow	Silver
HFS208	-8	HY	P0870	0.860/0.880	Blue	Silver
HFS210	-10	HY	P1015	1.005/1.025	Orange	Silver
HFS212	-12	HY	P1150	1.140/1.160	Green	Silver
HFS216	-16	HY	P1450	1.440/1.460	Black	Silver
HTB04	-4	Contact Parflex				
HTB06	-6	43	A06	0.865/0.885	Yellow	Black
HTB08	-8	43	A08	0.985/1.005	Blue	Black
HTB10	-10	43	A10	1.100/1.120	Orange	Black
HTB12	-12	43	A12	1.285/1.305	Green	Black
HTB16	-16	43	A16	1.630/1.650	Black	Black
M806	-6	43	M0850	0.840/0.860	Yellow	Silver
M808	-8	43	M1010	1.000/1.020	Blue	Silver
M810	-10	43	M1170	1.160/1.180	Orange	Silver

Parflex Crimp Dies can be identified by machined grooves in the top of dies: 55 Series has one groove, 58 Series has two grooves, 91N Series has three grooves and HY Series is flat. For 43 Series tooling and crimping information not listed above, refer to Parker Hose Products Catalog 4400, Section C.

The following tooling is used for crimping:

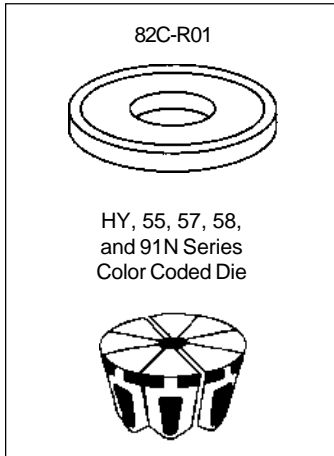

82C-R01 Silver Die Ring – to be used with HY, 55, 58, 57, and 91N Series fittings

80C-Axx Die Set - 43 Series
80C-Mxx - 43 Series
80C-Pxx Die Set - HY/55/57/58 Series
80C-Txx Die Set - 91N Series

Note: There are three (3) identification grooves in the top of the 91N Series dies. There are two (2) grooves in the top of the 58 Series dies and one (1) groove in the top of the 55 and 57 Series dies. The top of the HY Series dies is flat. For 43 Series tooling and crimping information, refer to Parker Hose Products Catalog 4400, Section C.

The HY, 55, 57, 58 and 91N dies are gold and color coded by size; 43 series dies are silver or gold and color coded by size. Refer to Die Selection Chart in the Parker Parflex Catalog 4660 or “Parflex Hose Crimp Assembly Tool Selection Chart” in this manual to determine which die set to use when crimping a particular hose size and type.

CAUTION: To ensure consistent quality, crimp diameters must be checked:

1. After first assembly
2. At regular intervals during production

If out of tolerance crimp diameters result, inspect all assemblies produced. **Never allow the use of hose assemblies with an incorrect crimp diameter.** If unable to determine the cause of the problem, call the appropriate Parker division:

Parker Parflex Division
Technical Service Department
(330) 298-4066 or (330) 296-2871
e-mail: dmay@parker.com

Parker Hose Products
Technical Department
(440) 943-5700

MiniKrimp™ Assembly Instructions for HY, 43, 55, 57, 58 and 91N Series Fittings



1. Place the hose next to the fitting and align it with the knurl marks in the fitting shell. Mark the length onto the hose. Push hose into the fitting until the mark on the hose is even with the end of the fitting shell (lubricate hose, if necessary).



2. Select proper die set. For Parflex hoses, see "Parflex Hose Crimp Assembly Tool Selection Chart" in this manual. **Note:** Die sets are color coded by size.

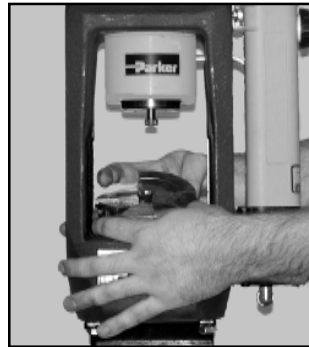

3a. Using a molybdenum disulfide type grease, apply a thin layer of grease to the die bowl.
 3b. Place unitized die set into die bowl.

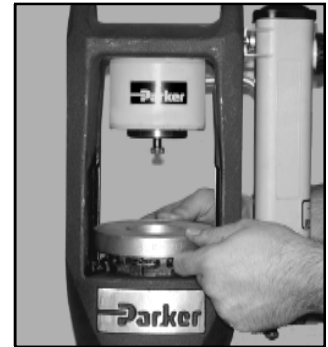

4. Place proper die ring on top of the selected die. See Parker PFD Catalog 4660 for proper die ring selection.



5. Slide pusher into place onto shoulder bolt.



6. Position the hose and fitting in dies from below.

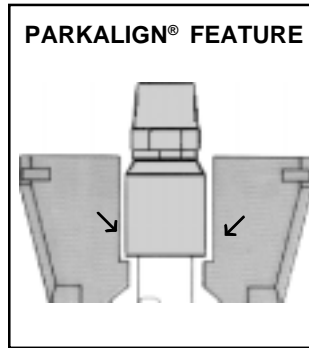

7. Rest bottom of coupling on die step using PARKALIGN® feature.



8. While holding hose and fitting into position on die step, begin pumping hand pump until die ring contacts base plate.



9. Release pressure, remove finished assembly. Check crimp diameter. See Parker PFD Catalog 4660 for correct crimp diameter measurements.



10. Measure crimp diameter of each fitting at the top, middle and bottom of the shell. Take measurements at a minimum of three places around the shell circumference. Verify crimp diameter is within tolerances. For Parflex hoses see "Parflex Hose Crimp Assembly Tool Selection Chart" in this manual for correct crimp diameters.

Note: Hose assemblies must be inspected for cleanliness and should be free of all foreign particles.

Note: Parker Hannifin will not accept responsibility for the operation of, or provide warranty coverage for, a crimper that is operated by a power unit other than equipment supplied by Parker Hannifin for the express purpose of operating that crimper.

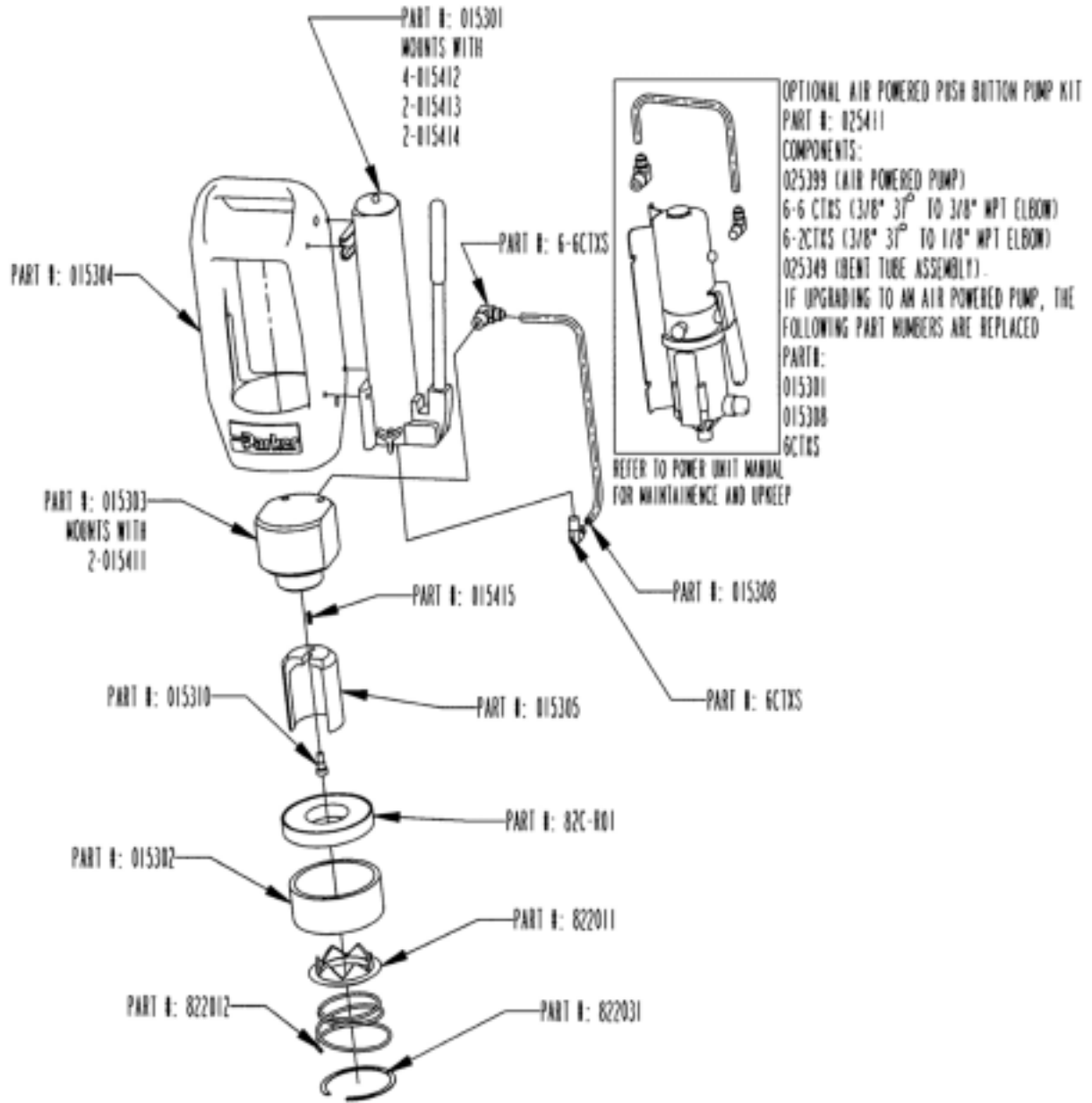

MiniKrimp Models (94C-001-PFD and 94C-002-PFD) consist of:

Part No.	Description	Qty.
015301	2 Speed Light Weight Hand Pump	1
015302	Hardened Steel Sleeve	1
015303	Custom Cylinder	1
015304	Aluminum Framed Machine	1
015305	Cup Pusher	1
015308	Bent Tube Assembly	1
015310	3/8" x 3/8" Shoulder Bolt	1
015415	Spring Plunger	1
6CTXS	3/8" 37° to 1/4" NPT Elbow	1
6-2CTXS	3/8" 37° to 1/8" NPT Elbow	1
6-6CTXS	3/8" 37° to 3/8" NPT Elbow	1

Part No.	Description	Qty.
822011	Die Separator	1
822012	Spring	1
822031	Retention Ring	1
82C-R01	Silver Die Ring	1
015411	3/8-16 18-8 SS SHCS 2.5" Long	2
015413	1/4-20 18-8 SS Lock Washer	2
015414	14-20 18-8 SS Flat Washer	2
015412	1/4-20 18-8 SS SHCS .75" Long	4
025349	Bent Tube Assembly	1
025399	Air Powered Pump	1

Assembling the MiniKrimp™ Air Over Hydraulic Pump Upgrade Kit

1. (IF APPLICABLE) Remove the hand pump and bent tube assembly from the body of the crimper. Do not take out the adapter in the cylinder as it is the same as the adapter used for the Air over Hydraulic Pump. The adapter will however need to be reoriented.
2. Screw (or reorient) the 6-6 CTXS adapter into the cylinder port and tighten until the fitting is facing in the upward direction. Do not loosen the adapter to reach the correct orientation as this may cause leakage.
3. Screw the 6-2 CTXS adapter into the pump and tighten until the fitting is facing the direction of the fill cap.
4. Mount the pump to the right side of the crimper as shown in the figure using two 1/4" bolt holes on the top of the crimper. Note that only the top two bolt holes are used.
5. Attach the 025399 bent tube assembly to the two adapters. The longer of the two ends of the tube will attach to the pump. Tighten the nuts of the bent tube to a minimum of 21 ft.-lbs.



MiniKrimp™ Assembly Instructions for HY, 43, 55, 57, 58 and 91N Series Fittings Using Air Over Hydraulic Pump

1. See steps 1 – 7 in “MiniKrimp™ Assembly Instructions for HY, 43, 55, 57, 58 and 91N Series Fittings.”
2. Hold black button located on pump below red lever until die ring contacts base plate.
3. Depress red lever to release pressure.
4. Measure crimp diameter of each fitting at the tip, middle and bottom of the shell. Take measurements at a minimum of three places around the shell circumference. Verify crimp diameter is within tolerances. For Parflex hoses see “Parflex Hose Crimp Assembly Tool Selection Chart” in this manual for correct crimp diameters.

Note: Hose assemblies must be inspected for cleanliness and should be free of all foreign particles. Parker Hannifin will not accept responsibility for the operation of, or provide warranty coverage for, a crimper that is operated by a power unit other than equipment supplied by Parker Hannifin for the express purpose of operating that crimper.

If you have a problem with your MiniKrimp Portable Crimping Machine....

First, check that the proper tooling, hose and fitting combinations are being used.

Then check the following recommendations. If the following suggestions do not remedy the problem, call the Parflex Technical Service Department (330) 298-4066 or (330) 296-2871.

Symptoms	Possible Causes	What to Do
Hand pump, air/hydraulic pump, electric pump, pump hose assembly, quick disconnect problems		Refer to Enerpac instruction sheets or call Enerpac at 1-800-433-2766; in Wisconsin 1-800-242-6636.
Coupling crimp diameter above or below	Wrong fitting style being used.	Only HY, 43, 55, 57, 58 and 91N Series fittings may be used with MiniKrimp™ machine. For 43 Series tooling and crimping information, refer to Parker Hose Products Catalog 4400, Section C.
	Wrong die ring being used.	Refer to die selection chart in the Parker PFD Catalog 4660 for correct die ring. NOTE: Refer to the latest Parker Parflex Catalog 4660 for approved hose and fitting styles and sizes.
	Pusher is not be bottomed out on die ring and base plate completely (usually inconsistent crimp diameters).	Lubricate die cavity with Factran EP-2 lithium grease, Dowel Corning GN assembly paste, or equivalent to prevent dies from sticking in bowl. Bottom out the pusher on the die ring completely. Also check for proper bottoming by placing a piece of paper between die ring and base plate. If properly bottomed, you should not be able to remove paper. Vent must be open for Hand pump and Air over Hydraulic pump prior to use.
	Pump relief valve set too low.	Adjust relief valve setting to 10,000 psi. For assistance, contact Enerpac's Technical Service Center at 1-800-433-2766; in Wisconsin 1-800-242-6636.
	High or low voltage.	Call a qualified electrician.
	Low on oil.	Refill oil reservoir with Enerpac recommended oil.
	Crimp dies, die rings damaged, worn, or faulty.	Visually inspect all wear surfaces for raised metal dents or gouges. Replace damaged die sets and die rings. Worn or faulty die sets will crimp above or below specifications by the same amount with and without the die ring. Replace worn or faulty die sets. Lubricate the die cavity in the base plate frequently with Factran EP-2 lithium grease, Dowel Corning GN assembly paste, or equivalent to prevent wear.
Die cavity in base plate worn or faulty.	Check crimp diameter of several different sizes of die sets with and without the black spacer ring. If all crimp diameters are out of specification by the same amount, the die cavity in the base plate may be out of specification. Contact Parflex Technical Service Dept. (330) 298-4066 or (330) 296-2871 for repair. Lubricate the die cavity in base plate frequently with Factran EP-2 lithium grease, Dowel Corning GN assembly paste, or equivalent to prevent wear.	



Parker Safety Guide

for Selecting and Using Hose, Tubing, Fittings and Related Accessories

Parker Publication No. 4400-B.1

Revised: May 2002

WARNING: Failure or improper selection or improper use of hose, tubing, fittings, assemblies or related accessories (“Products”) can cause death, personal injury and property damage. Possible consequences of failure or improper selection or improper use of these Products include but are not limited to:

- Fittings thrown off at high speed.
- High velocity fluid discharge.
- Explosion or burning of the conveyed fluid.
- Electrocutation from high voltage electric power lines.
- Contact with suddenly moving or falling objects that are controlled by the conveyed fluid.
- Injections by high-pressure fluid discharge.
- Dangerously whipping Hose.
- Contact with conveyed fluids that may be hot, cold, toxic or otherwise injurious.
- Sparking or explosion caused by static electricity buildup or other sources of electricity.
- Sparking or explosion while spraying paint or flammable liquids.
- Injuries resulting from inhalation, ingestion or exposure to fluids.

Before selecting or using any of these Products, it is important that you read and follow the instructions below. Only Hose from Parker’s Stratoflex Products Division is approved for in flight aerospace applications, and no other Hose can be used for such in flight applications.

1.0 GENERAL INSTRUCTIONS

1.1 Scope: This safety guide provides instructions for selecting and using (including assembling, installing, and maintaining) these Products. For convenience, all rubber and/or thermoplastic products commonly called “hose” or “tubing” are called “Hose” in this safety guide. All assemblies made with Hose are called “Hose Assemblies”. All products commonly called “fittings” or “couplings” are called “Fittings”. All related accessories (including crimping and swaging machines and tooling) are called “Related Accessories”. This safety guide is a supplement to and is to be used with, the specific Parker publications for the specific Hose, Fittings and Related Accessories that are being considered for use.

1.2 Fail-Safe: Hose, and Hose Assemblies and Fittings can and do fail without warning for many reasons. Design all systems and equipment in a fail-safe mode, so that failure of the Hose or Hose Assembly or Fitting will not endanger persons or property.

1.3 Distribution: Provide a copy of this safety guide to each person that is responsible for selecting or using Hose and Fitting products. Do not select or use Parker Hose or Fittings without thoroughly reading and understanding this safety guide as well as the specific Parker publications for the products considered or selected.

1.4 User Responsibility: Due to the wide variety of operating conditions and applications for Hose and Fittings, Parker and its distributors do not represent or warrant that any particular Hose or Fitting is suitable for any specific end use system. This safety guide does not analyze all technical parameters that must be considered in selecting a product. The user, through its own analysis and testing, is solely responsible for:

- Making the final selection of the Hose and Fitting.
- Assuring that the user’s requirements are met and that the application presents no health or safety hazards.
- Providing all appropriate health and safety warnings on the equipment on which the Hose and Fittings are used.
- Assuring compliance with all applicable government and industry standards.

1.5 Additional Questions: Call the appropriate Parker technical service department if you have any questions or require any additional information. See the Parker publication for the product being considered or used, or call 1-800-CPARKER, or go to www.parker.com, for telephone numbers of the appropriate technical service department.

2.0 HOSE AND FITTING SELECTION INSTRUCTIONS

2.1 Electrical Conductivity: Certain applications require that the Hose be nonconductive to prevent electrical current flow. Other applications require the Hose and the Fitting and the Hose/Fitting interface to be sufficiently conductive to drain off static electricity. Extreme care must be exercised when selecting Hose and Fittings for these or any other applications in which electrical conductivity or nonconductivity is a factor.

The electrical conductivity or nonconductivity of Hose and Fittings is dependent upon many factors and may be susceptible to change.

These factors include but are not limited to the various materials used to make the Hose and the Fittings, Fitting finish (some Fitting finishes are electrically conductive while others are nonconductive), manufacturing methods (including moisture control), how the Fittings contact the Hose, age and amount of deterioration or damage or other changes, moisture content of the Hose at any particular time, and other factors.

The following are considerations for electrically nonconductive and conductive Hose. For other applications consult the individual catalog pages and the appropriate industry or regulatory standards for proper selection.

2.1.1 Electrically Nonconductive Hose: Certain applications require that the Hose be nonconductive to prevent electrical current flow or to maintain electrical isolation. For these applications that require Hose to be electrically nonconductive, including but not limited to applications near high voltage electric lines, only special nonconductive Hose can be used. The manufacturer of the equipment in which the nonconductive Hose is to be used must be consulted to be certain that the Hose and Fittings that are selected are proper for the application. Do not use any Parker Hose or Fitting for any such application requiring nonconductive Hose, including but not limited to applications near high voltage electric lines, unless (i) the application is expressly approved in the Parker technical publication for the product, (ii) the Hose is marked “nonconductive”, and (iii) the manufacturer of the equipment on which the Hose is to be used specifically approves the particular Parker Hose and Fitting for such use.

2.1.2 Electrically Conductive Hose: Parker manufactures special Hose for certain applications that require electrically conductive Hose. Parker manufactures special Hose for conveying paint in airless paint spraying applications. This Hose is labeled “Electrically Conductive Airless Paint Spray Hose” on its layline and packaging. This Hose must be properly connected to the appropriate Parker Fittings and properly grounded in order to dissipate dangerous static charge buildup, which occurs in all airless paint spraying applications. Do not use any other Hose for airless paint spraying, even if electrically conductive. Use of any other Hose or failure to properly connect the Hose can cause a fire or an explosion resulting in death, personal injury, and property damage.

Parker manufactures a special Hose for certain compressed natural gas (“CNG”) applications where static electricity buildup may occur. Parker CNG Hose assemblies comply with AGA Requirements 1-93, “Hoses for Natural Gas Vehicles and Fuel Dispensers”. This Hose is labeled “Electrically Conductive for CNG Use” on its layline and packaging. This Hose must be properly connected to the appropriate Parker Fittings and properly grounded in order to dissipate dangerous static charge buildup, which occurs in, for example, high velocity CNG dispensing or transfer. Do not use any other Hose for CNG applications where static charge buildup may occur, even if electrically conductive. Use of other Hoses in CNG applications or failure to properly connect or ground this Hose

(Continued)

can cause a fire or an explosion resulting in death, personal injury, and property damage. Care must also be taken to protect against CNG permeation through the Hose wall. See section 2.6, Permeation, for more information. Parker CNG Hose is intended for dispenser and vehicle use at a maximum temperature of 180°F. Parker CNG Hose should not be used in confined spaces or unventilated areas or areas exceeding 180°F. Final assemblies must be tested for leaks. CNG Hose Assemblies should be tested on a monthly basis for conductivity per AGA 1-93.

Parker manufactures special Hose for aerospace in-flight applications. Aerospace in-flight applications employing Hose to transmit fuel, lubricating fluids and hydraulic fluids require a special Hose with a conductive inner tube. This Hose for in-flight applications is available only from Parker's Stratoflex Products Division. Do not use any other Parker Hose for in-flight applications, even if electrically conductive. Use of other Hoses for in-flight applications or failure to properly connect or ground this Hose can cause a fire or an explosion resulting in death, personal injury, and property damage. These Hose assemblies for in-flight applications must meet all applicable aerospace industry, aircraft engine, and aircraft requirements.

- 2.2 Pressure:** Hose selection must be made so that the published maximum recommended working pressure of the Hose is equal to or greater than the maximum system pressure. Surge pressures or peak transient pressures in the system must be below the published maximum working pressure for the Hose. Surge pressures and peak pressures can usually only be determined by sensitive electrical instrumentation that measures and indicates pressures at millisecond intervals. Mechanical pressure gauges indicate only average pressures and cannot be used to determine surge pressures or peak transient pressures. Published burst pressure ratings for Hose is for manufacturing test purposes only and is no indication that the Product can be used in applications at the burst pressure or otherwise above the published maximum recommended working pressure.
- 2.3 Suction:** Hoses used for suction applications must be selected to insure that the Hose will withstand the vacuum and pressure of the system. Improperly selected Hose may collapse in suction application.
- 2.4 Temperature:** Be certain that fluid and ambient temperatures, both steady and transient, do not exceed the limitations of the Hose. Temperatures below and above the recommended limit can degrade Hose to a point where a failure may occur and release fluid. Properly insulate and protect the Hose Assembly when routing near hot objects (e.g. manifolds). Do not use any Hose in any application where failure of the Hose could result in the conveyed fluids (or vapors or mist from the conveyed fluids) contacting any open flame, molten metal, or other potential fire ignition source that could cause burning or explosion of the conveyed fluids or vapors.
- 2.5 Fluid Compatibility:** Hose Assembly selection must assure compatibility of the Hose tube, cover, reinforcement, and Fittings with the fluid media used. See the fluid compatibility chart in the Parker publication for the product being considered or used. This information is offered only as a guide. Actual service life can only be determined by the end user by testing under all extreme conditions and other analysis. Hose that is chemically compatible with a particular fluid must be assembled using Fittings and adapters containing likewise compatible seals.
- 2.6 Permeation:** Permeation (that is, seepage through the Hose) will occur from inside the Hose to outside when Hose is used with gases, liquid and gas fuels, and refrigerants (including but not limited to such materials as helium, diesel fuel, gasoline, natural gas, or LPG). This permeation may result in high concentrations of vapors which are potentially flammable, explosive, or toxic, and in loss of fluid. Dangerous explosions, fires, and other hazards can result when using the wrong Hose for such applications. The system designer must take into account the fact that this permeation will take place and must not use Hose if this permeation could be hazardous. The system designer must take into account all legal, government, insurance, or any other special regulations which govern the use of fuels and refrigerants. Never use a Hose even though the fluid compatibility is acceptable without considering the poten-

tial hazardous effects that can result from permeation through the Hose Assembly.

Permeation of moisture from outside the Hose to inside the Hose will also occur in Hose assemblies, regardless of internal pressure. If this moisture permeation would have detrimental effects (particularly, but not limited to refrigeration and air conditioning systems), incorporation of sufficient drying capacity in the system or other appropriate system safeguards should be selected and used.

- 2.7 Size:** Transmission of power by means of pressurized fluid varies with pressure and rate of flow. The size of the components must be adequate to keep pressure losses to a minimum and avoid damage due to heat generation or excessive fluid velocity.
- 2.8 Routing:** Attention must be given to optimum routing to minimize inherent problems (kinking or flow restriction due to Hose collapse, twisting of the Hose, proximity to hot objects or heat sources).
- 2.9 Environment:** Care must be taken to insure that the Hose and Fittings are either compatible with or protected from the environment (that is, surrounding conditions) to which they are exposed. Environmental conditions including but not limited to ultraviolet radiation, sunlight, heat, ozone, moisture, water, salt water, chemicals, and air pollutants can cause degradation and premature failure.
- 2.10 Mechanical Loads:** External forces can significantly reduce Hose life or cause failure. Mechanical loads which must be considered include excessive flexing, twist, kinking, tensile or side loads, bend radius, and vibration. Use of swivel type Fittings or adapters may be required to insure no twist is put into the Hose. Unusual applications may require special testing prior to Hose selection.
- 2.11 Physical Damage:** Care must be taken to protect Hose from wear, snagging, kinking, bending smaller than minimum bend radius, and cutting, any of which can cause premature Hose failure. Any Hose that has been kinked or bent to a radius smaller than the minimum bend radius, and any Hose that has been cut or is cracked or is otherwise damaged, should be removed and discarded.
- 2.12 Proper End Fitting:** See instructions 3.2 through 3.5. These recommendations may be substantiated by testing to industry standards such as SAE J517 for hydraulic applications, or MIL-A-5070, AS1339, or AS3517 for Hoses from Parker's Stratoflex Products Division for aerospace applications.
- 2.13 Length:** When establishing a proper Hose length, motion absorption, Hose length changes due to pressure, and Hose and machine tolerances and movement must be considered.
- 2.14 Specifications and Standards:** When selecting Hose and Fittings, government, industry, and Parker specifications and recommendations must be reviewed and followed as applicable.
- 2.15 Hose Cleanliness:** Hose components may vary in cleanliness levels. Care must be taken to insure that the Hose Assembly selected has an adequate level of cleanliness for the application.
- 2.16 Fire Resistant Fluids:** Some fire resistant fluids that are to be conveyed by Hose require use of the same type of Hose as used with petroleum base fluids. Some such fluids require a special Hose, while a few fluids will not work with any Hose at all. See instructions 2.5 and 1.5. The wrong Hose may fail after a very short service. In addition, all liquids but pure water may burn fiercely under certain conditions, and even pure water leakage may be hazardous.
- 2.17 Radiant Heat:** Hose can be heated to destruction without contact by such nearby items as hot manifolds or molten metal. The same heat source may then initiate a fire. This can occur despite the presence of cool air around the Hose.
- 2.18 Welding or Brazing:** When using a torch or arc welder in close proximity to hydraulic lines, the hydraulic lines should be removed or shielded with appropriate fire resistant materials. Flame or weld spatter could burn through the Hose and possibly ignite escaping fluid resulting in a catastrophic failure. Heating of plated parts, including Hose Fittings and adapters, above 450°F (232°C) such as during welding, brazing, or soldering may emit deadly gases.
- 2.19 Atomic Radiation:** Atomic radiation affects all materials used in Hose assemblies. Since the long-term effects may be unknown, do not expose Hose assemblies to atomic radiation.
- 2.20 Aerospace Applications:** The only Hose and Fittings that may be used for in-flight aerospace applications are Hose available from

(Continued)

Parker's Stratoflex Products Division. Do not use any other Hose or Fittings for in-flight applications. Do not use any Hose or Fittings from Parker's Stratoflex Products Division with any other Hose or Fittings, unless expressly approved in writing by the engineering manager or chief engineer of Stratoflex Products Division and verified by the user's own testing and inspection to aerospace industry standards.

- 2.21 Unlocking Couplings:** Ball locking couplings or other couplings with disconnect sleeves can unintentionally disconnect if they are dragged over obstructions or if the sleeve is bumped or moved enough to cause disconnect. Threaded couplings should be considered where there is a potential for accidental uncoupling.
- 3.0 HOSE AND FITTING ASSEMBLY AND INSTALLATION INSTRUCTIONS**
- 3.1 Component Inspection:** Prior to assembly, a careful examination of the Hose and Fittings must be performed. All components must be checked for correct style, size, catalog number, and length. The Hose must be examined for cleanliness, obstructions, blisters, cover looseness, kinks, cracks, cuts or any other visible defects. Inspect the Fitting and sealing surfaces for burrs, nicks, corrosion or other imperfections. Do NOT use any component that displays any signs of nonconformance.
- 3.2 Hose and Fitting Assembly:** Do not assemble a Parker Fitting on a Parker Hose that is not specifically listed by Parker for that Fitting, unless authorized in writing by the engineering manager or chief engineer of the appropriate Parker division. Do not assemble a Parker Fitting on another manufacturer's Hose or a Parker Hose on another manufacturer's Fitting unless (i) the engineering manager or chief engineer of the appropriate Parker division approves the Assembly in writing or that combination is expressly approved in the appropriate Parker literature for the specific Parker product, and (ii) the user verifies the Assembly and the application through analysis and testing. For Parker Hose that does not specify a Parker Fitting, the user is solely responsible for the selection of the proper Fitting and Hose Assembly procedures. See instruction 1.4. The Parker published instructions must be followed for assembling the Fittings on the Hose. These instructions are provided in the Parker Fitting catalog for the specific Parker Fitting being used, or by calling 1-800-CPARKER, or at www.parker.com.
- 3.3 Related Accessories:** Do not crimp or swage any Parker Hose or Fitting with anything but the listed swage or crimp machine and dies in accordance with Parker published instructions. Do not crimp or swage another manufacturer's Fitting with a Parker crimp or swage die unless authorized in writing by the engineering manager or chief engineer of the appropriate Parker division.
- 3.4 Parts:** Do not use any Parker Fitting part (including but not limited to socket, shell, nipple, or insert) except with the correct Parker mating parts, in accordance with Parker published instructions, unless authorized in writing by the engineering manager or chief engineer of the appropriate Parker division.
- 3.5 Reusable/Permanent:** Do not reuse any field attachable (reusable) Hose Fitting that has blown or pulled off a Hose. Do not reuse a Parker permanent Hose Fitting (crimped or swaged) or any part thereof. Complete Hose Assemblies may only be reused after proper inspection under section 4.0. Do not assemble Fittings to any previously used hydraulic Hose that was in service, for use in a fluid power application.
- 3.6 Pre-Installation Inspection:** Prior to installation, a careful examination of the Hose Assembly must be performed. Inspect the Hose Assembly for any damage or defects. Do NOT use any Hose Assembly that displays any signs of nonconformance.
- 3.7 Minimum Bend Radius:** Installation of a Hose at less than the minimum listed bend radius may significantly reduce the Hose life. Particular attention must be given to preclude sharp bending at the Hose to Fitting juncture. Any bending during installation at less than the minimum bend radius must be avoided. If any Hose is kinked during installation, the Hose must be discarded.
- 3.8 Twist Angle and Orientation:** Hose Assembly installation must be such that relative motion of machine components does not produce twisting.
- 3.9 Securement:** In many applications, it may be necessary to restrain, protect, or guide the Hose to protect it from damage by

unnecessary flexing, pressure surges, and contact with other mechanical components. Care must be taken to insure such restraints do not introduce additional stress or wear points.

- 3.10 Proper Connection of Ports:** Proper physical installation of the Hose Assembly requires a correctly installed port connection insuring that no twist or torque is transferred to the Hose when the Fittings are being tightened or otherwise during use.
- 3.11 External Damage:** Proper installation is not complete without insuring that tensile loads, side loads, kinking, flattening, potential abrasion, thread damage, or damage to sealing surfaces are corrected or eliminated. See instruction 2.10.
- 3.12 System Checkout:** All air entrapment must be eliminated and the system pressurized to the maximum system pressure (at or below the Hose maximum working pressure) and checked for proper function and freedom from leaks. Personnel must stay out of potential hazardous areas while testing and using.
- 3.13 Routing:** The Hose Assembly should be routed in such a manner so if a failure does occur, the escaping media will not cause personal injury or property damage. In addition, if fluid media comes in contact with hot surfaces, open flame, or sparks, a fire or explosion may occur. See section 2.4.
- 4.0 HOSE AND FITTING MAINTENANCE AND REPLACEMENT INSTRUCTIONS**
- 4.1** Even with proper selection and installation, Hose life may be significantly reduced without a continuing maintenance program. The severity of the application, risk potential from a possible Hose failure, and experience with any Hose failures in the application or in similar applications should determine the frequency of the inspection and the replacement for the Products so that Products are replaced before any failure occurs. A maintenance program must be established and followed by the user and, at minimum, must include instructions 4.2 through 4.7.
- 4.2 Visual Inspection Hose/Fitting:** Any of the following conditions require immediate shut down and replacement of the Hose Assembly:
- Fitting slippage on Hose,
 - Damaged, cracked, cut or abraded cover (any reinforcement exposed);
 - Hard, stiff, heat cracked, or charred Hose;
 - Cracked, damaged, or badly corroded Fittings;
 - Leaks at Fitting or in Hose;
 - Kinked, crushed, flattened or twisted Hose; and
 - Blistered, soft, degraded, or loose cover.
- 4.3 Visual Inspection All Other:** The following items must be tightened, repaired, corrected or replaced as required:
- Leaking port conditions;
 - Excess dirt buildup;
 - Worn clamps, guards or shields; and
 - System fluid level, fluid type, and any air entrapment.
- 4.4 Functional Test:** Operate the system at maximum operating pressure and check for possible malfunctions and leaks. Personnel must avoid potential hazardous areas while testing and using the system. See section 2.2.
- 4.5 Replacement Intervals:** Hose assemblies and elastomeric seals used on Hose Fittings and adapters will eventually age, harden, wear and deteriorate under thermal cycling and compression set. Hose Assemblies and elastomeric seals should be inspected and replaced at specific replacement intervals, based on previous service life, government or industry recommendations, or when failures could result in unacceptable downtime, damage, or injury risk. See section 1.2.
- 4.6 Hose Inspection and Failure:** Hydraulic power is accomplished by utilizing high-pressure fluids to transfer energy and do work. Hoses, Fittings, and Hose Assemblies all contribute to this by transmitting fluids at high pressures. Fluids under pressure can be dangerous and potentially lethal and, therefore, extreme caution must be exercised when working with fluids under pressure and handling the Hoses transporting the fluids. From time to time, Hose Assemblies will fail if they are not replaced at proper time intervals. Usually these failures are the result of some form of misapplication, abuse, wear, or failure to perform proper maintenance. When Hoses

(Continued)

Safety Guide

fail, generally the high-pressure fluids inside escape in a stream which may or may not be visible to the user. Under no circumstances should the user attempt to locate the leak by "feeling" with their hands or any other part of their body. High-pressure fluids can and will penetrate the skin and cause severe tissue damage and possibly loss of limb. Even seemingly minor hydraulic fluid injection injuries must be treated immediately by a physician with knowledge of the tissue damaging properties of hydraulic fluid.

If a Hose failure occurs, immediately shut down the equipment and leave the area until pressure has been completely released from the Hose Assembly. Simply shutting down the hydraulic pump may or may not eliminate the pressure in the Hose Assembly. Many times check valves, etc., are employed in a system and can cause pressure to remain in a Hose Assembly even when pumps or equipment are not operating. Tiny holes in the Hose, commonly known as pinholes, can eject small, dangerously powerful but hard to see streams of hydraulic fluid. It may take several minutes or even hours for the pressure to be relieved so that the Hose Assembly may be examined safely.

Once the pressure has been reduced to zero, the Hose Assembly may be taken off the equipment and examined. It must always be replaced if a failure has occurred. Never attempt to patch or repair

a Hose Assembly that has failed. Consult the nearest Parker distributor or the appropriate Parker division for Hose Assembly replacement information.

Never touch or examine a failed Hose Assembly unless it is obvious that the Hose no longer contains fluid under pressure. The high-pressure fluid is extremely dangerous and can cause serious and potentially fatal injury.

- 4.7 Elastomeric seals:** Elastomeric seals will eventually age, harden, wear and deteriorate under thermal cycling and compression set. Elastomeric seals should be inspected and replaced.
- 4.8 Refrigerant gases:** Special care should be taken when working with refrigeration systems. Sudden escape of refrigerant gases can cause blindness if the escaping gases contact the eye and can cause freezing or other severe injuries if it contacts any other portion of the body.
- 4.9 Compressed natural gas (CNG):** Parker CNG Hose Assemblies should be tested after installation and before use, and at least on a monthly basis per AGA 1-93 Section 4.2 "Visual Inspection Hose/Fitting". The recommended procedure is to pressurize the Hose and check for leaks and to visually inspect the Hose for damage.
- 4.10** Matches, candles, open flame or other sources of ignition shall not be used for Hose inspection. Leak check solutions should be rinsed off after use.

Material Safety Data Sheets (MSDS) are available upon request.

Federal OSHA regulation 29 CFR 1910.1200 requires that we transmit to our customers Material Safety Data Sheets for all material covered under the law. If you are an employer in SIC 20-39 who has not yet received them, you are required to obtain them from us and provide the information to employees as directed in Section (b) of the regulation. Please contact the Parflex Technical Service Department at 330-298-4066 (phone) or 330-296-8433 (FAX).

Offer of Sale

The items described in this document and other documents or descriptions provided by Parker Hannifin Corporation, its subsidiaries and its authorized distributors are hereby offered for sale at prices to be established by Parker Hannifin Corporation, its subsidiaries and its authorized distributors. This offer and its acceptance by any customer ("Buyer") shall be governed by all of the following Terms and Conditions. Buyer's order for any such items, when communicated to Parker Hannifin Corporation, its subsidiary or an authorized distributor ("Seller") verbally or in writing, shall constitute acceptance of this offer.

1. Terms and Conditions of Sale: All descriptions, quotations, proposals, offers, acknowledgments, acceptances and sales of Seller's products are subject to and shall be governed exclusively by the terms and conditions stated herein. Buyer's acceptance of any offer to sell is limited to these terms and conditions. Any terms or conditions in addition to, or inconsistent with those stated herein, proposed by Buyer in any acceptance of an offer by Seller, are hereby objected to. No such additional, different or inconsistent terms and conditions shall become part of the contract between Buyer and Seller unless expressly accepted in writing by Seller. Seller's acceptance of any offer to purchase by Buyer is expressly conditional upon Buyer's assent to all the terms and conditions stated herein, including any terms in addition to, or inconsistent with those contained in Buyer's offer. Acceptance of Seller's products shall in all events constitute such assent.

2. Payment: Payment shall be made by Buyer net 30 days from the date of delivery of the items purchased hereunder. Amounts not timely paid shall bear interest at the maximum rate permitted by law for each month or portion thereof that the Buyer is late in making payment. Any claims by Buyer for omissions or shortages in a shipment shall be waived unless Seller receives notice thereof within 30 days after Buyer's receipt of the shipment.

3. Delivery: Unless otherwise provided on the face hereof, delivery shall be made F.O.B. Seller's plant. Regardless of the method of delivery, however, risk of loss shall pass to Buyer upon Seller's delivery to a carrier. Any delivery dates shown are approximate only and Seller shall have no liability for any delays in delivery.

4. Warranty: Seller warrants that the items sold hereunder shall be free from defects in material or workmanship for a period of 18 months from date of shipment from Parker Hannifin Corporation. **THIS WARRANTY COMPRISES THE SOLE AND ENTIRE WARRANTY PERTAINING TO ITEMS PROVIDED HEREUNDER. SELLER MAKES NO OTHER WARRANTY, GUARANTEE, OR REPRESENTATION OF ANY KIND WHATSOEVER. ALL OTHER WARRANTIES, INCLUDING BUT NOT LIMITED TO, MERCHANTABILITY AND FITNESS FOR PURPOSE, WHETHER EXPRESS, IMPLIED, OR ARISING BY OPERATION OF LAW, TRADE USAGE, OR COURSE OF DEALING ARE HEREBY DISCLAIMED. NOTWITHSTANDING THE FOREGOING, THERE ARE NO WARRANTIES WHATSOEVER ON ITEMS BUILT OR ACQUIRED WHOLLY OR PARTIALLY, TO BUYER'S DESIGNS OR SPECIFICATIONS.**

5. Limitation Of Remedy: SELLER'S LIABILITY ARISING FROM OR IN ANY WAY CONNECTED WITH THE ITEMS SOLD OR THIS CONTRACT SHALL BE LIMITED EXCLUSIVELY TO REPAIR OR REPLACEMENT OF THE ITEMS SOLD OR REFUND OF THE PURCHASE PRICE PAID BY BUYER, AT SELLER'S SOLE OPTION. IN NO EVENT SHALL SELLER BE LIABLE FOR ANY INCIDENTAL, CONSEQUENTIAL OR SPECIAL DAMAGES OF ANY KIND OR NATURE WHATSOEVER, INCLUDING BUT NOT LIMITED TO LOST PROFITS ARISING FROM OR IN ANY WAY CONNECTED WITH THIS AGREEMENT OR ITEMS SOLD HEREUNDER, WHETHER ALLEGED TO ARISE FROM BREACH OF CONTRACT, EXPRESS OR IMPLIED WARRANTY, OR IN TORT, INCLUDING WITHOUT LIMITATION, NEGLIGENCE, FAILURE TO WARN OR STRICT LIABILITY.

6. Changes, Reschedules and Cancellations: Buyer may request to modify the designs or specifications for the items sold hereunder as well as the quantities and delivery dates thereof, or may request to cancel all or part of this order, however, no such requested modification or cancellation shall become part of the contract between Buyer and Seller unless accepted by Seller in a written amendment to this Agreement. Acceptance of any such requested modification or cancellation shall be at Seller's discretion, and shall be upon such terms and conditions as Seller may require.

7. Special Tooling: A tooling charge may be imposed for any special tooling, including without limitation, dies, fixtures, molds and patterns, acquired to manufacture items sold pursuant to this contract. Such special tooling shall be and remain Seller's property notwithstanding payment of any charges by Buyer. In no event will Buyer acquire any interest in apparatus belonging to Seller which is utilized in the manufacture of the items sold hereunder, even if such apparatus has been specially converted or adapted for such manufacture and notwithstanding any charges paid by Buyer. Unless otherwise agreed, Seller shall have the right to alter, discard or otherwise dispose of any special tooling or other property in its sole discretion at any time.

8. Buyer's Property: Any designs, tools, patterns, materials, drawings, confidential information or equipment furnished by Buyer or any other items which become Buyer's property, may be considered obsolete and may be destroyed by Seller after two (2) consecutive years have elapsed without Buyer placing an order for the items which are manufactured using such property, Seller shall not be responsible for any loss or damage to such property while it is in Seller's possession or control.

9. Taxes: Unless otherwise indicated on the face hereof, all prices and charges are exclusive of excise, sales, use, property, occupational or like taxes which may be imposed by any taxing authority upon the manufacture, sale or delivery of the items sold hereunder. If any such taxes must be paid by Seller or if Seller is liable for the collection of such tax, the amount thereof shall be in addition to the amounts for the items sold. Buyer agrees to pay all such taxes or to reimburse Seller therefore upon receipt of its invoice. If Buyer claims exemption from any sales, use or other tax imposed by any taxing authority, Buyer shall save Seller harmless from and against any such tax, together with any interest or penalties thereon which may be assessed if the items are held to be taxable.

10. Indemnity For Infringement of Intellectual Property Rights: Seller shall have no liability for infringement of any patents, trademarks, copyrights, trade dress, trade secrets or similar rights except as provided in this Part 10. Seller will defend and indemnify Buyer against allegations of infringement of U.S. Patents, U.S. Trademarks, copyrights, trade dress and trade secrets (hereinafter 'Intellectual Property Rights'). Seller will defend at its expense and will pay the cost of any settlement or damages awarded in an action brought against Buyer based on an allegation that an item sold pursuant to this contract infringes the Intellectual Property Rights of a third party. Seller's obligation to defend and indemnify Buyer is contingent on Buyer notifying Seller within ten (10) days after Buyer becomes aware of such allegations of infringement, and Seller having sole control over the defense of any allegations or actions including all negotiations for settlement or compromise. If an item sold hereunder is subject to a claim that it infringes the Intellectual Property Rights of a third party, Seller may, at its sole expense and option, procure for Buyer the right to continue using said item, replace or modify said item so as to make it noninfringing, or offer to accept return of said item and return the purchase price less a reasonable allowance for depreciation. Notwithstanding the foregoing, Seller shall have no liability for claims of infringement based on information provided by Buyer, or directed to items delivered hereunder for which the designs are specified in whole or part by Buyer, or infringements resulting from the modification, combination or use in a system of any item sold hereunder. The foregoing provisions of this Part 10 shall constitute Seller's sole and exclusive liability and Buyer's sole and exclusive remedy for infringement of Intellectual Property Rights.

If a claim is based on information provided by Buyer or if the design for an item delivered hereunder is specified in whole or in part by Buyer, Buyer shall defend and indemnify Seller for all costs, expenses or judgments resulting from any claim that such item infringes any patent, trademark, copyright, trade dress, trade secret or any similar right.

11. Force Majeure: Seller does not assume the risk of and shall not be liable for delay or failure to perform any of Seller's obligations by reason of circumstances beyond the reasonable control of Seller (hereinafter 'Events of Force Majeure'). Events of Force Majeure shall include without limitation, accidents, acts of God, strikes or labor disputes, acts, laws, rules or regulations of any government or government agency, fires, floods, delays or failures in delivery of carriers or suppliers, shortages of materials and any other cause beyond Seller's control.

12. Entire Agreement/Governing Law: The terms and conditions set forth herein, together with any amendments, modifications and any different terms or conditions expressly accepted by Seller in writing, shall constitute the entire Agreement concerning the items sold, and there are no oral or other representations or agreements which pertain thereto. This Agreement shall be governed in all respects by the law of the State of Ohio. No actions arising out of the sale of the items sold hereunder or this Agreement may be brought by either party more than two (2) years after the cause of action accrues.

9/91-P



Parker Hannifin Corporation
Parflex Division
1300 North Freedom Street
Ravenna, Ohio 44266 USA
Tel: (330) 298-4066
(330) 296-2871
Fax: (330) 296-8433
www.parflex.com
Parker Printing Services 4/2003

