

Triplex Ceramic
Plunger Pump
Operating Instructions/
Manual

Models GP5132, GP5136 & GP5145

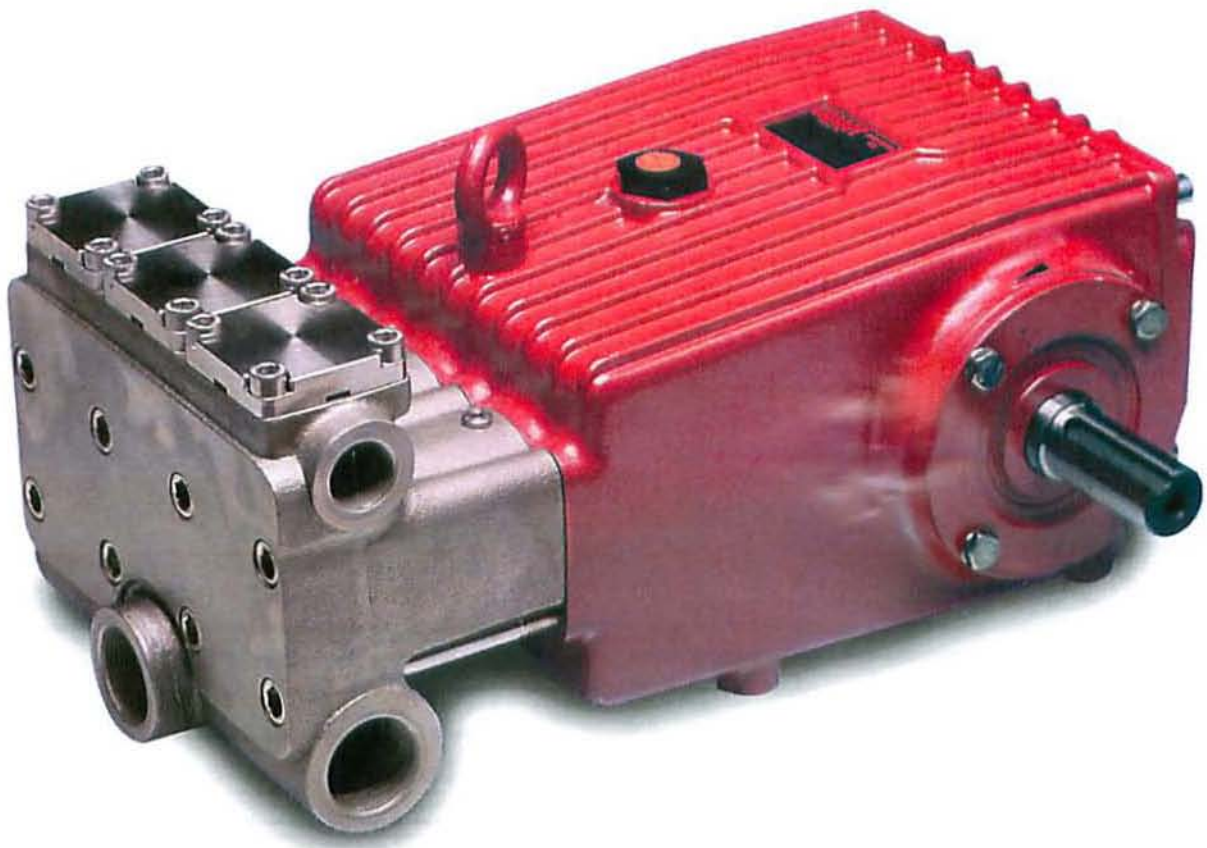

GIANT

Contents:

Installation Instructions:	page 2
Pump Specifications:	pages 3-5
Parts List/Exploded View:	pages 6-7
Kits/Torque Specs:	page 8
Trouble Shooting:	page 9
Repair Instructions:	page 10-11
Dimensions:	back page
Warranty Information	back page

INSTALLATION INSTRUCTIONS

Installation of the Giant Industries, Inc., pump is not a complicated procedure, but there are some basic steps common to all pumps. The following information is to be considered as a general outline for installation. If you have unique requirements, please contact Giant Industries, Inc. or your local distributor for assistance.

1. The pump should be installed flat on a base to a maximum of a 15 degree angle of inclination to ensure optimum lubrication.
2. The inlet to the pump should be sized for the flow rate of the pump with no unnecessary restrictions that can cause cavitation. Teflon tape should be used to seal all joints. If pumps are to be operated at temperatures in excess of 140° F, it is important to insure a positive head to the pump to prevent cavitation.
3. The discharge plumbing from the pump should be properly sized to the flow rate to prevent line pressure loss to the work area. It is essential to provide a safety bypass valve between the pump and the work area to protect the pump from pressure spikes in the event of a blockage or the use of a shut-off gun.
4. Use of a dampener is necessary to minimize pulsation at drive elements, plumbing, connections, and other system areas. The use of a dampener with Giant Industries, Inc. pumps is optional, although recommended by Giant Industries, Inc. to further reduce system pulsation. Dampeners can also reduce the severity of pressure spikes that occur in systems using a shut-off gun. A dampener must be positioned downstream from the unloader.
5. Crankshaft rotation on Giant Industries, Inc. pumps should be made in the direction designated by the arrows on the pump crankcase. Reverse rotation may be safely achieved by following a few guidelines available upon request from Giant Industries, Inc. Required horsepower for system operation can be obtained from the charts on pages 3-5.
6. Before beginning operation of your pumping system, remember: Check that the crankcase and seal areas have been properly lubricated per recommended schedules. Do not run the pump dry for extended periods of time. Cavitation will result in severe damage. Always remember to check that all plumbing valves are open and that pumped media can flow freely to the inlet of the pump.

Finally, remember that high pressure operation in a pump system has many advantages. But, if it is used carelessly and without regard to its potential hazard, it can cause serious injury.

IMPORTANT OPERATING CONDITIONS

Failure to comply with any of these conditions invalidates the warranty

1. Prior to initial operation, add oil to crankcase so that oil level is between the two lines on the oil dipstick. **DO NOT OVERFILL. SAE 80 or SAE 90 Industrial Gear oil may be used.** Crankcase oil should be changed after the first 50 hours of operation, then at regular intervals of 500 hours or less depending on operating conditions.
2. Pump operation must not exceed rated pressure, volume, or RPM. A pressure relief device must be installed in the discharge of the system.
3. Acids, alkalines, or abrasive fluids cannot be pumped unless approval in writing is obtained before operation from Giant Industries, Inc.
4. Run the pump dry approximately 10 seconds to drain the water before exposure to freezing temperatures.

NOTE: Contact Giant Industries for Service School Information. Phone: (419)-531-4600

Specifications

Model GP5132

Volume	Up to 29 GPM
Discharge Pressure	Up to 3000 PSI
Speed	Up to 1000 RPM
Inlet Pressure	Up to 145 PSI
Plunger Diameter	32 mm
Plunger Stroke	46mm
Crankshaft Diameter	35mm x 10mm key
Crankshaft Mounting	Either side
Shaft Rotation	Top of pulley towards manifold
Temperature of Pumped Fluids	Up to 140 °F
Inlet Ports	(3) 1-1/2" BSP
Discharge Ports	(2) 1" BSP
Weight	179 lbs.
Crankcase Oil Capacity	1.2 Gal.
Fluid End Material	Cast Iron

Consult the factory for special requirements that must be met if the pump is to operate beyond one or more of the limits specified above.

GP5132 HORSEPOWER REQUIREMENTS						
RPM	GPM	1000 PSI	1500 PSI	2000 PSI	2500 PSI	3000 PSI
600	17.4	12	18	24	30	36
700	20.3	14	21	28	35	42
900	26.1	18	27	36	45	54
1000	29	20	30	40	50	60

HORSEPOWER RATINGS:

The rating shown are the power requirements for the pump. Gas engine power outputs must be approximately twice the pump power requirements shown above.

We recommend a 1.15 service factor be specified when selecting an electric motor as the power source. To compute specific pump horsepower requirements, use the following formula:

$$HP = (GPM \times PSI) / 1450$$

SPECIAL NOTE:
 FOR CONTINUAL OPERATION, THE SPEED OF THE PUMP MUST BE LIMITED TO 700 RPM, AND THE MAXIMUM PRESSURE OF THE PUMP MUST BE REDUCED BY 10%.

Specifications

Model GP5136

Volume	Up to 35 GPM
Discharge Pressure	Up to 2200 PSI
Speed	Up to 945 RPM
Inlet Pressure	Up to 145 PSI
Plunger Diameter	36mm
Plunger Stroke	46mm
Crankshaft Diameter	35mm x 10mm key
Crankshaft Mounting	Either side
Shaft Rotation	Top of pulley towards manifold
Temperature of Pumped Fluids	Up to 140 °F
Inlet Ports	(3) 1-1/2" BSP
Discharge Ports	(2) 1" BSP
Weight	179 lbs.
Crankcase Oil Capacity	1.2 Gal.
Fluid End Material	Cast Iron

Consult the factory for special requirements that must be met if the pump is to operate beyond one or more of the limits specified above.

GP5136 HORSEPOWER REQUIREMENTS						
RPM	GPM	1000 PSI	1500 PSI	1800 PSI	2000 PSI	2200 PSI
700	26	18	27	33	36.3	39.4
750	28	19	29	35	39	42.5
800	30	21	31	37	41	45.5
850	32	22	33	40	44	48.6
945	35	24.1	36.2	43.4	48.2	53.1

HORSEPOWER RATINGS:
 The rating shown are the power requirements for the pump. Gas engine power outputs must be approximately twice the pump power requirements shown above.

We recommend a 1.15 service factor be specified when selecting an electric motor as the power source. To compute specific pump horsepower requirements, use the following formula:

$$HP = (GPM \times PSI) / 1450$$

SPECIAL NOTE:
 FOR CONTINUAL OPERATION, THE SPEED OF THE PUMP MUST BE LIMITED TO 700 RPM, AND THE MAXIMUM PRESSURE OF THE PUMP MUST BE REDUCED BY 10%.

Specifications

Model GP5145

Volume	Up to 43.3 GPM
Discharge Pressure	Up to 1500 PSI
Speed	Up to 750 RPM
Inlet Pressure	Up to 145 PSI
Plunger Diameter	45mm
Plunger Stroke	46mm
Crankshaft Diameter	35mm x 10mm key
Crankshaft Mounting	Either side
Shaft Rotation	Top of pulley towards manifold
Temperature of Pumped Fluids	Up to 140 °F
Inlet Ports	(3) 1-1/2" BSP
Discharge Ports	(2) 1" BSP
Weight	179 lbs.
Crankcase Oil Capacity	1.2 Gal.
Fluid End Material	Cast Iron

Consult the factory for special requirements that must be met if the pump is to operate beyond one or more of the limits specified above.

GP5145 HORSEPOWER REQUIREMENTS					
RPM	GPM	1000 PSI	1100 PSI	1300 PSI	1500 PSI
550	31.9	22	24.2	28.6	33
600	34.9	24.1	26.5	31.3	36.1
650	37.8	26	28.7	33.9	39.1
700	40.6	28	30.8	36.4	42
750	43.3	29.9	32.8	38.8	44.8

HORSEPOWER RATINGS:

The rating shown are the power requirements for the pump. Gas engine power outputs must be approximately twice the pump power requirements shown above.

We recommend a 1.15 service factor be specified when selecting an electric motor as the power source. To compute specific pump horsepower requirements, use the following formula:

$$HP = (GPM \times PSI) / 1450$$

SPECIAL NOTE:
 FOR CONTINUAL OPERATION, THE SPEED OF THE PUMP MUST BE LIMITED TO 700 RPM, AND THE MAXIMUM PRESSURE OF THE PUMP MUST BE REDUCED BY 10%.

GP5100 Series PARTS LIST

<u>ITEM</u>	<u>PART</u>	<u>DESCRIPTION</u>	<u>QTY.</u>	<u>ITEM</u>	<u>PART</u>	<u>DESCRIPTION</u>	<u>QTY.</u>
1	13266	Crankcase	1	37B	07653	O-Ring (GP5132)	3
2	13000	Oil Filler Plug Assembly	1	39	13026	Pressure Ring (GP5132)	3
3	07186	Oil Sight Glass Assy.	1	39	07142	Pressure Ring (GP5136)	3
4	13267	Crankcase Cover	1	39	13293	Pressure Ring (GP5145)	3
5	13268	O-Ring	1	40	13027	V-Sleeve (GP5132)	6
8	07105	Oil Dip Stick	1	40	07144	V-Sleeve (GP5136)	6
9	01009	O-Ring, Dip Stick	1	40	13294	V-Sleeve (GP5145)	6
10	13270	Inner Hexagon Screw	4	41	13028	Sleeve Support Ring (GP5132)	3
11	13134	Spring Washer	4	41	07146	Sleeve Support Ring (GP5136)	3
12	07703	Drain Plug G 3/4"	1	41	13296	Sleeve Support Ring (GP5145)	3
13	13269	Gasket, Drain Plug	1	42	07173	Tension Spring (GP5132)	3
14	13271	Bearing Cover	2	42	07147	Tension Spring (GP5136)	3
15	13272	Radial Shaft Seal	2	42	13297	Tension Spring (GP5145)	3
16	08182	O-Ring	2	42A	13298	Spring Guide (GP5136 only)	3
17	13358	Hexagon Screw	8	43	13300	Valve Casing	1
18	13134	Spring Washer	8	46	13302	Suction Valve Assy.	3
20	13206	Taper Roller Bearing	2	46A	12055	O-Ring	1*
20A	13207	Fitting Disc (Shim)	5	46B	08059	O-Ring	1*
21	13273	Shaft Protector	1	46C	13304	Suction Valve Seat	1*
22	13274	Crankshaft	1	46D	13306	Valve Plate	1*
23	13275	Fitting Key	1	46E	13307	Valve Spring	1*
24	13276	Connecting Rod Assy.	3	46F	13308	Spring Tension Cap	1*
25	13279	Crosshead Assy.	3	46G	13309	Spacer Pipe	1*
28	13281	Crosshead Pin	3	47	13311	Discharge Valve Assy.	3
29A	07125	Centering Sleeve	3	47A	13289	O-Ring	1*
29B	13022	Plunger Pipe (GP5132)	3	47B	07700	O-Ring	1*
29B	07130	Plunger Pipe (GP5136)	3	47C	13314	Discharge Valve Seat	1*
29B	13283	Plunger Pipe (GP5145)	3	47D	13306	Valve Plate	1*
29C	07131	Tension Screw	3	47E	13307	Valve Spring	1*
29D	07755	Oil Scraper	3	47F	13308	Spring Tension Cap	1*
30	13282	Copper Ring	3	48	13316	Plug	3
31	13284	Radial Shaft Seal	3	48A	07008	Inner Hexagon Screw	12
35	13359	Seal Sleeve (GP5132)	3	48B	07740	O-Ring	3
35	13288	Seal Sleeve (GP5136)	3	48C	07232	Pressure Ring	3
35	13287	Seal Sleeve (GP5145)	3	49	13362	Inner Hexagon Screw	8
35A	13289	O-Ring (GP5136)	3	52	13363	Disc for Crankshaft	1
35A	13286	O-Ring (GP5145)	3	53	13358	Hexagon Screw	1
35B	08183	O-Ring	3	54	13321	Plug G 1"	1
36	13360	Grooved Ring (GP5132)	3	55	13322	Plug G 1-1/2"	2
36	13291	Grooved Ring (GP5136)	3				
36	13290	Grooved Ring (GP5145)	3				
37	13361	Seal Case (GP5132)	3				
37A	07700	O-Ring (GP5132)	3				

* Per Valve Assembly

Exploded View - GP5100 Series

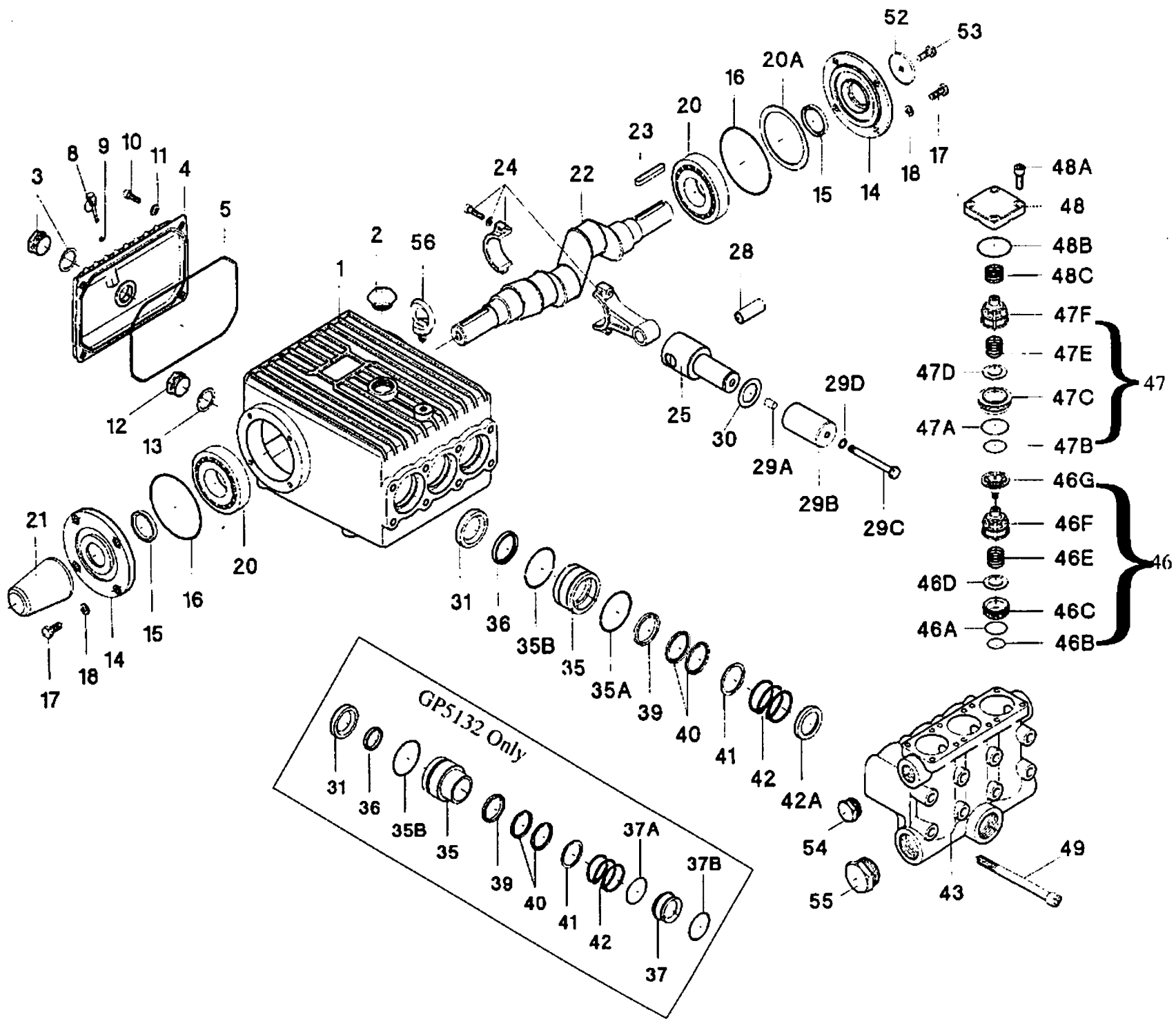

GP5100 SERIES REPAIR KITS

Plunger Packing Kits

GP5132 #09290

<u>Qty.</u>	<u>Part #</u>	<u>Description</u>
3	08183	O-Ring
3	13360	Grooved Ring
6	13027	V-Sleeve

GP5136 #09229

<u>Qty.</u>	<u>Part #</u>	<u>Description</u>
3	13289	O-Ring
3	08183	O-Ring
3	13291	Grooved Ring
6	07144	V-Sleeve

GP5145 #09228

<u>Qty.</u>	<u>Part #</u>	<u>Description</u>
3	13286	O-Ring
3	08183	O-Ring
3	13290	Grooved Ring
6	13294	V-Sleeve

Valve Assembly Kits

Inlet Valve Kit, GP5100 Series, #09231

<u>Qty.</u>	<u>Part #</u>	<u>Description</u>
1	12055	O-Ring
1	08059	O-Ring
1	13304	Valve Seat
1	13306	Valve Plate
1	13307	Valve Spring

Discharge Valve Kit, GP5100 Series, # 09232

<u>Qty.</u>	<u>Part #</u>	<u>Description</u>
1	13289	O-Ring
1	07700	O-Ring
1	13314	Valve Seat
1	13306	Valve Plate
1	13307	Valve Spring

Oil Seal Kit

GP5100 Series, #09230

<u>Qty.</u>	<u>Part #</u>	<u>Description</u>
3	13284	Oil Seal

GP5100 SERIES TORQUE SPECIFICATIONS

<u>Position</u>	<u>Item#</u>	<u>Description</u>	<u>Torque Amount (ft.-lbs)</u>
24	13276	Connecting Rod Assy.	26
29C	07131	Tension Screw, Plunger	26
48A	07008	Inner Hexagon Screw, Plug	35
49	13362	Inner Hexagon Screw, Valve Casing	85

PUMP SYSTEM MALFUNCTION

<u>MALFUNCTION</u>	<u>CAUSE</u>	<u>REMEDY</u>
The Pressure and/ or the Delivery Drops	Worn packing seals Broken valve spring Belt slippage Worn or Damaged nozzle Fouled discharge valve Fouled inlet strainer Worn or Damaged hose Worn or Plugged relief valve on pump Cavitation pump for restrictions Unloader	Replace packing seals Replace spring Tighten or Replace belt Replace nozzle Clean valve assembly Clean strainer Repair/Replace hose Clean, Reset, and Replace worn parts Check suction lines on inlet of Check for proper operation
Water in crankcase	High humidity Worn seals	Reduce oil change interval Replace seals
Noisy Operation	Worn bearings Cavitation	Replace bearings, Refill crankcase oil with recommended lubricant Check inlet lines for restrictions and/or proper sizing
Rough/Pulsating Operation with Pressure Drop	Worn packing Inlet restriction Accumulator pressure Unloader Cavitation	Replace packing Check system for stoppage, air leaks, correctly sized inlet plumbing to pump Recharge/Replace accumulator Check for proper operation Check inlet lines for restrictions and/or proper size
Pump Pressure as Drop at gun Rated, Pressure	Restricted discharge plumbing	Re-size discharge plumbing to flow rate of pump
Excessive Leakage	Worn plungers Worn packing/seals Excessive vacuum Cracked plungers Inlet pressure too high	Replace plungers Adjust or Replace packing seals Reduce suction vacuum Replace plungers Reduce inlet pressure
High Crankcase Temperature	Wrong Grade of oil Improper amount of oil in crankcase	Giant oil is recommended Adjust oil level to proper amount

REPAIR INSTRUCTIONS

Note: Always take time to lubricate all metal and nonmetal parts with a light film of oil before reassembly. This step will ensure proper fit, at the same time protecting the pump's non-metal parts (i.e., the elastomers) from cutting and scoring.

To Check Valves

1. Screw-out inner hexagon screws (48A) with an allen wrench. Remove discharge plugs (48) with a screw driver. Check O-Rings (48B) on discharge plugs and replace as necessary.
2. Pull out Pressure Ring (48C). Remove the Spring Tension Cap (47F) from the discharge Valve Plate (47D) lying underneath by screwing in the 10mm screw. Take out the Valve Spring (47E) and Valve Plate (47D). Pull out the Discharge Valve Seat (47C) by means of slide hammer. Check sealing areas of the Valve Plate (47D) and the Valve Seat (47C) for damage and replace worn parts. Check O-Rings (47A and 47B) and replace as necessary.
3. Screw Spacer Pipe (46G) out of the Spring Tension Cap (46F) located in the suction valve lying underneath. Remove the Suction Valve Assembly (46) by screwing in a 10mm screw. Check O-Rings (46A and 46B) and replace as necessary. If the Suction Valve Seat (46C) remains in the Valve Casing (43), remove it with a slide hammer. Check the sealing areas of the Suction Valve Plate (46D) and the Suction Valve Seat (46C) for damage and replace worn parts.
4. After reassembling the above items, tighten the Inner Hexagon Screws (48A) to 35 ft.-lbs.

To Check Seals and Plunger Pipes

1. Loosen the eight Inner Hexagon Screws (49) and pull off the Valve Casing (43) to the front. Pull Seal Sleeves (35) out of the guides in the crankcase and over the plunger pipes (29B). Remove Sleeve Support Ring (41), Sleeves (40) and Grooved Rings (36). Replace worn parts as necessary.
2. If a Plunger Pipe (29B) is worn out, loosen the Tension Screw (29C) and pull off the Plunger Pipe to the front. Clean the contact surfaces of the Crosshead Assembly (25) thoroughly. Place the new plunger pipe carefully through oiled seals back into the seal case. Check O-Rings (35A and 35B) on the Seal Sleeves (35) and replace as necessary.
3. Push the Seal Sleeves (35) together with the Plunger Pipe (29B) back into the crankcase guide. Turn the crankshaft (22) carefully until the Crosshead Assembly (25) comes up against the Plunger Pipe. Put a new Oil Scraper (29D) onto the Tension Screw (29C). Cover the thread of the Tension Screw and the Oil Scraper and apply a liquid adhesive such as Lock-Tite. Tighten Tension Screw to 26 ft.-lbs..

Important!!

Do not get any adhesive between the Plunger Pipe (29B) and the Centering Sleeve (29A). The Plunger Pipe should not be strained by excessive force on the Tension Screw (29C) or through damage to the front surface of the Plunger. If these conditions are ignored, the Plunger Pipe will probably break.

4. Tighten the Inner Hexagon Screws (49) to the Valve Casing (43) to 85 ft.-lbs.

To Disassemble Gear End

1. Loosen Inner Hexagon Screws (49) for the Valve Casing (43) with an allen wrench. Carefully remove Valve Casing from the Crankcase (1).
2. Loosen Inner Hexagon Screws (10) for the Crankcase Cover (4) with an allen wrench and remove Crankcase Cover.
3. Loosen Hexagon Screws (17) for the Bearing Covers (14) with a wrench and remove Bearing Cover.
4. Drain oil from the Crankcase (1) by removing Drain Plug (12) with a 3/4" wrench.
5. Loosen Connecting Rod Screws (24) with an allen wrench. Push the stems of the connecting rods as far as possible into the crosshead guides. Carefully push out the Radial Shaft Seals(31).

Important!!

Connecting Rods (24) are marked for identification. Do not twist Connecting Rod halves. Connecting Rods must be reinstalled in the same position on the Crankshaft (22) journals.

6. While slightly turning the Crankshaft (22), hit it out carefully to one side with a rubber hammer.

Important!!

Do not bend Connecting Rod (24) shank.

7. Check the surfaces of the Crankshaft (22), Connecting Rods (24), Crosshead Assemblies (25) as well as the Radial Shaft Seals (15 and 31) and Taper Roller Bearings (20).

To Reassemble Gear End

1. Using a soft tool, such as brass or wooden dowel, press in the outer bearing ring until it lines up with the outer edge of the bearing hole. Assemble the Bearing Cover (14) together with the Shaft Seal (15) and O-Ring (16).
2. Fit the Crankshaft (22) with pressed-on bearing parts through the bearing hole on the opposite side. Press in outer bearing ring and push it inwards with the Bearing Cover (14) while keeping the Crankshaft in the vertical position and turning it slowly so that the taper rollers of the bearings touch the edge of the outer bearing ring.
3. Adjust axial bearing clearance with Fitting Discs (20A) which are 0.1mm each. The Crankshaft (22) should turn easily with very little clearance. Tighten Inner Hexagon Screws on the Connecting Rods (24) to 26 ft.-lbs..

Important!!

There should be enough clearance for the Connecting Rods (24) to move sideways a little on the journals.

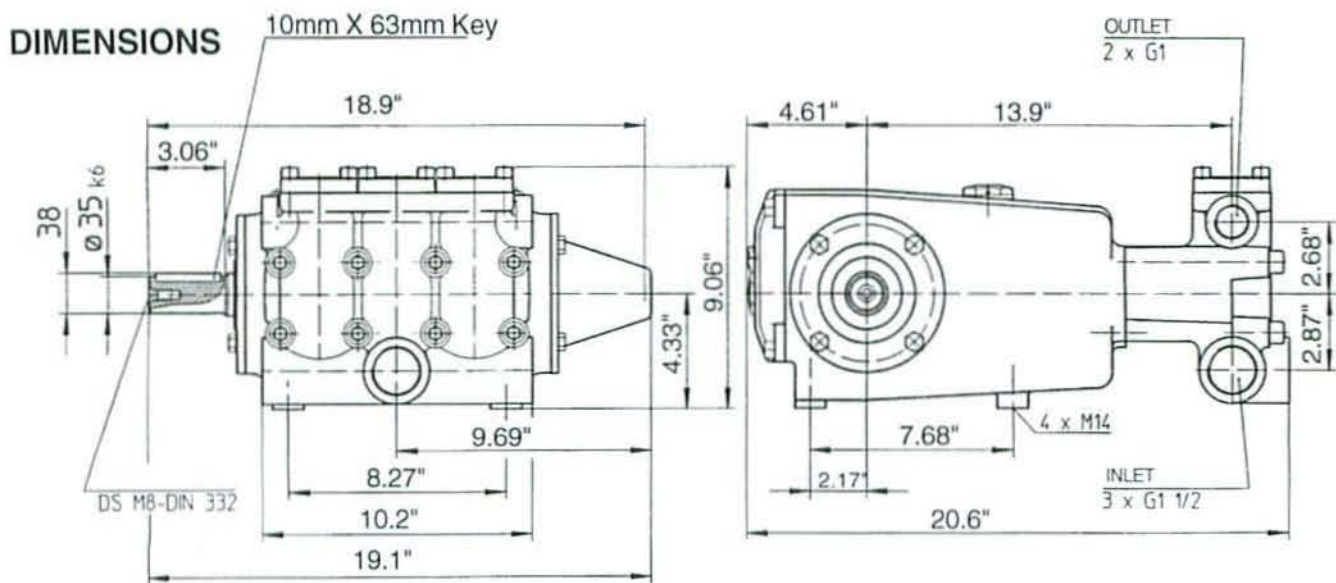

GIANT INDUSTRIES LIMITED WARRANTY

Giant Industries, Inc. pumps and accessories are warranted by the manufacturer to be free from defects in workmanship and material as follows:

1. For portable pressure washers and car wash applications, the discharge manifolds will never fail, period. If they ever fail, we will replace them free of charge. Our other pump parts, used in portable pressure washers and in car wash applications, are warranted for five years from the date of shipment for all pumps used in NON-SALINE, clean water applications.
2. One (1) year from the date of shipment for all other Giant industrial and consumer pumps.
3. Six (6) months from the date of shipment for all rebuilt pumps.
4. Ninety (90) days from the date of shipment for all Giant accessories.

This warranty is limited to repair or replacement of pumps and accessories of which the manufacturer's evaluation shows were defective at the time of shipment by the manufacturer. The following items are NOT covered or will void the warranty:

1. Defects caused by negligence or fault of the buyer or third party.
2. Normal wear and tear to standard wear parts.
3. Use of repair parts other than those manufactured or authorized by Giant.
4. Improper use of the product as a component part.
5. Changes or modifications made by the customer or third party.
6. The operation of pumps and or accessories exceeding the specifications set forth in the Operations Manuals provided by Giant Industries, Inc.

Liability under this warranty is on all non-wear parts and limited to the replacement or repair of those products returned freight prepaid to Giant Industries which are deemed to be defective due to workmanship or failure of material. A Returned Goods Authorization (R.G.A.) number and completed warranty evaluation form is required prior to the return to Giant Industries of all products under warranty consideration. Call (419)-531-4600 or fax (419)-531-6836 to obtain an R.G.A. number.

Repair or replacement of defective products as provided is the sole and exclusive remedy provided hereunder and the MANUFACTURER SHALL NOT BE LIABLE FOR FURTHER LOSS, DAMAGES, OR EXPENSES, INCLUDING INCIDENTAL AND CONSEQUENTIAL DAMAGES DIRECTLY OR INDIRECTLY ARISING FROM THE SALE OR USE OF THIS PRODUCT.

THE LIMITED WARRANTY SET FORTH HEREIN IS IN LIEU OF ALL OTHER WARRANTIES OR REPRESENTATION, EXPRESS OR IMPLIED, INCLUDING WITHOUT LIMITATION ANY WARRANTIES OR MERCHANTABILITY OR FITNESS FOR A PARTICULAR PURPOSE AND ALL SUCH WARRANTIES ARE HEREBY DISCLAIMED AND EXCLUDED BY THE MANUFACTURER.

